

## Seasonal changes in platform use by adult farmbred silver foxes (*Vulpes vulpes*)

Hannu Korhonen and Paavo Niemelä

Agricultural Research Centre of Finland, Fur Farming Research Station, FIN-69100 Kannus, Finland

Seasonal changes in platform use (Wooden U-type platform, area 3090 cm<sup>2</sup>) were studied during one year in adult farmbred silver foxes (*Vulpes vulpes*) by daytime scan sampling observations and 24-h video recordings. Platform use was found to be lowest during the coldest part of the year (winter, late autumn) and highest in mid-summer (July). The seasonal pattern in platform use obtained by the scan samplings was in agreement with that obtained by video recordings. Platform use was sex-related being significantly ( $p < 0.001$ ) higher in females than males. Circadian distribution of platform use was rather similar for both sexes. Hourly use was highest from 4 to 5 a.m. and lowest at about 8–9 a.m. when farm work started. Platforms were mostly used for sleeping and the least for jumping. The animals' needs for rest, observation and seclusion required by the European Convention were met fairly well by the presently studied platform type. This is demonstrated by its rather high amount of general use, and because it functioned appropriately as a place for observation and rest. Based on the present data, wooden U-type platforms can be recommended for practical farming purposes, particularly outside the winter period.

**Key words:** resting shelf, season, farm fox, animal welfare, environmental enrichment, wooden U-type platform

### Introduction

Farmed silver foxes (*Vulpes vulpes*) have conventionally been housed in bare wire-mesh cages without any shelter beyond the shed roof. Usually, nestboxes have only been placed inside the cages of breeding and lactating vixens from April to June. It has been recently emphasized that such housing is insufficient in terms of animal welfare not only because the animals are exposed to seasonal changes in environmental conditions, but inasmuch as barren farm cages do not ne-

cessarily provide animals with enough activating stimuli and challenges (Jeppesen and Pedersen 1990, Braastad 1992, Bakken et al. 1994, Korhonen and Niemelä 1995). Furthermore, The Standing Committee of the European Convention on the Protection of Animals Kept for Farming Purposes has issued a recommendation whereby each weaned fox should permanently be provided a secluded area, such as a suitable nestbox or platform, on which it can rest and observe the environment (European Convention 1991). Whole-year nestboxes have already been experimentally tested with promising results,

*Korhonen, H. & Niemelä, P.: Seasonal changes in platform use by adult farmed silver foxes (Vulpes vulpes)*

indicating that nestboxes advance animal welfare by reducing stress and fear (Jeppesen and Pedersen 1991, 1992). However, there are no continuous whole-year studies on platform use by silver foxes.

Recent short-term experiments have shown that several factors affect platform use (Mononen et al. 1993, Bakken et al. 1994, Korhonen and Niemelä 1994). For instance, wide variations have been found in the amount of use between different platform types and design constructions (Harri et al. 1991, 1992, Pedersen and Jeppesen 1993, Korhonen and Niemelä 1993, 1994, 1995, Korhonen et al. 1995, 1996). Large platforms with slightly U or V shaped bottoms have proved to be the most favoured models (Korhonen and Niemelä 1994), while both wood and net appear to be equally acceptable as platform materials (Korhonen et al. 1995, Korhonen and Niemelä 1995). In addition, blue and silver foxes have been found to prefer open platforms over walled ones because the former construction offers a better view of the environment (Mononen et al. 1993, 1995a, Korhonen and Niemelä 1995). If platforms are not introduced before adulthood, however, they will be used much less than by animals with platform experience already as juveniles (Korhonen and Niemelä 1995, Korhonen et al. 1995). Furthermore, it is crucial to remember that platform use is not constant but changes over time (Mononen et al. 1993) and most likely seasonally (Bakken et al. 1994, Korhonen and Niemelä 1994). Results from a comprehensive whole-year study on blue foxes showed that platform use varied significantly seasonally, being highest in summer and lowest in winter (Korhonen et al. 1996). Previous studies on silver foxes have not been carried out on a year-round basis, but have only lasted 4–5 months. Therefore, to what extent platform use varies seasonally, or if some other unambiguous explanation for the observed variations exists is not known. To optimize the welfare of farmed silver foxes, however, it would be important to determine the extent and reasons underlying seasonal changes in platform use.

The present study sought to: (1) determine

to what extent the use and function of platforms vary seasonally in farmed silver foxes, (2) elucidate sex differences in platform use, (3) clarify what purposes platforms are used for and, (4) quantify the extent of circadian variation in seasonal platform use.

## Material and methods

### General managements

The present experiments were carried out in 1994 at the Fur Farming Research Station of Kannus from January 1st to December 31st. The experimental animals (28 males, 28 females) were adult silver foxes born in May 1993. All animals had been exposed to platforms since weaning. The animals were housed singly inside a two-row shed in wire-mesh cages measuring 107 cm wide x 110 cm long x 70 cm high each. All animals remained healthy throughout the study period. The foxes were weighed with a Lario 30 kg balance (accuracy  $\pm 20$  g) about once a month (Figure 1). Ambient air temperatures were recorded by a minimum/maximum thermometer located inside the shed. Average of daily minimum and maximum temperatures represents the mean temperature of the day in question. Outdoor conditions during the experimental period are presented in Figure 1.

Freshly mixed fox feed manufactured by the local feed kitchen was supplied once a day (1 p.m.) from a feed dispenser machine. Feed portions (400–600 g/animal/day) and compositions were adjusted according to the seasonally recommended feeding standards of the Finnish Fur Breeders' Association (Berg 1986).

### Platform construction

A schematic picture of the platform type studied is presented in Figure 2. The experimental platforms (103 cm long x 30 cm wide; area 3090 cm<sup>2</sup>)

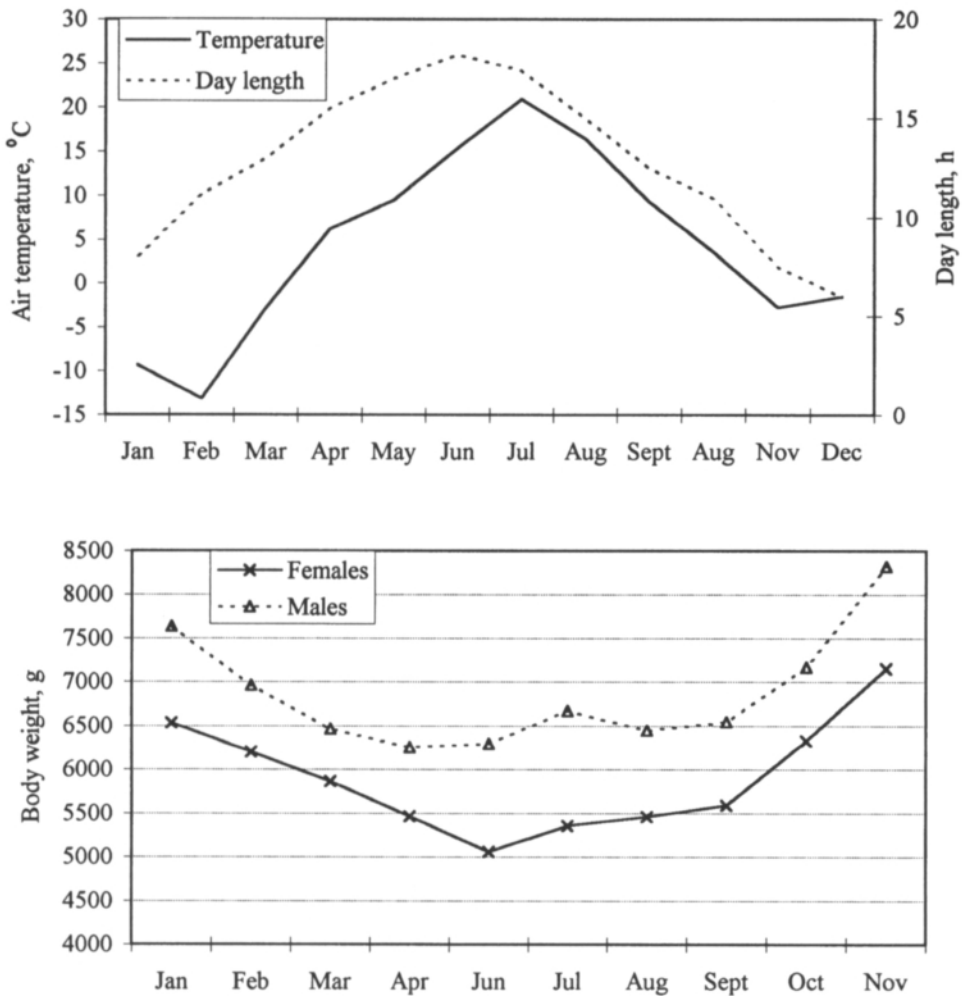

Fig. 1. Above: Mean temperatures and day lengths at the experimental farm. Below: Seasonal changes in mean body weights of female and male silver foxes.

were constructed of wood (22 mm x 125 mm; thickness x width) with 10 cm high walls at each end. The shape of the base of the platform slightly resembled the letter U (maximum depth 20 mm). This platform had been found to be the most favoured type in a previous study (Korhonen and Niemelä 1994), and was therefore selected for the present whole-year investigation. Platforms were placed on the shorter side of the cage with the end of the platform facing the aisle of the shed 23 cm below the cage roof. Platforms

were cleaned once a week to remove faeces and urine.

### Monitoring of platform use

Platform use was monitored by the following two methods: (1) continuous 24-hour recording by video camera equipment (CCD video camera 720, Bische UB-480 time-lapse tape recorder, Koyo monitor, Bische 12-300 infra-red light:

Korhonen, H. & Niemelä, P.: Seasonal changes in platform use by adult farmed silver foxes (*Vulpes vulpes*)

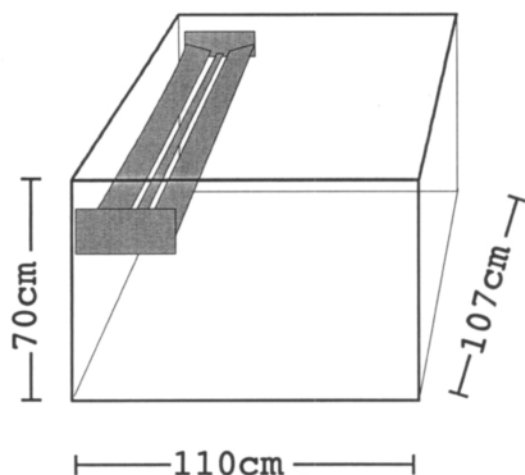

← Aisle of the shed →

Fig. 2. Schematic picture of the studied platform type and its location in the cage. The platform was constructed of wood (area 3090 cm<sup>2</sup>) and has a slightly U-shaped bottom.

500 W). Ten males and ten females were studied by means of the video recordings. Each animal was filmed continuously for 24-h each month during the one year period. The only exceptions were the months of January and October when the recordings were cancelled due to technical problems. Behavioural patterns were analyzed from the video tapes and then grouped into the following categories: jumping onto/off the platform (duration < 1 min, describing an instant of a change in position), lying on the platform (1–10 min), and sleeping on the platform (> 10 min) (Korhonen and Niemelä 1993). Data were also analyzed in terms of use per 24-h and for each hour of the 24-h circadian cycle (Korhonen et al. 1995).

(2) Daytime platform use was determined by scanning observations carried out three times a day (8 a.m., 12 a.m. and 3 p.m.), except on Fridays when observations were only performed at 8 a.m. and 12 a.m., due to the shorter workday. For the visual scanning, the observer walked quietly and slowly past the row of cages and

manually recorded the location of each fox (whether on the platform or not) (Pedersen and Jeppesen 1993). For example, when standing in front of cage No.2, the location of the fox in cage No.3 was recorded and so forth. If the animal fled during the observation, the location of the fox before it fled was recorded. Daily scanning observations of each month were summed up. Platform use was thus defined as the number of times a fox was recorded to be on the platform for each month out of the total number of observations for that month (Korhonen et al. 1995).

Because both video and scanning observation data deviated from the normal distribution, the actual results were presented as medians with 1st and 3rd quartile intervals.

### Statistical methods

Repeated measurements were made for each fox in different months. Typically, the set of observations for one subject tended to be intercorrelated, i.e. covariances between measurements within a subject tended to deviate from zero. These interdependencies were taken into account when modelling the data. In the present study, the mixed model approach was applied to the repeated measurements (Jones 1993).

Video and daytime scanning observation data were analyzed separately. Video data analyses were based on the following model:

$$Y_{ijk} = \mu + S_j + P_k + SP_{jk} + e_{ijk}$$

where

$Y_{ijk}$  = time of platform use for fox  $i$  of sex  $j$  during month  $k$

$\mu$  = constant

$S_j$  = effect of sex

$P_k$  = effect of month

$SP_{jk}$  = interaction of sex and month

$e_{ijk}$  = residual, assumed to be independent and multivariate normal with the means 0 and arbitrary covariance matrices  $\Sigma$ .

Scan sampling data was analyzed similarly, but here  $Y_{ijk}$  = the percentage of observations on the platform for fox  $i$  of sex  $j$  during month  $k$ .

Platform use, as a dependent variable in all analyses, was transformed with the common logarithm ( $\log(y + 1)$ ) to achieve a normal distribution and homogeneity of variance (Korhonen et al. 1996). Parameters of the models were estimated by the residual maximum likelihood (REML) estimation method.

Several covariance structures of the repeated measurements were fitted and the best one chosen by comparing several potential structures by the likelihood ratio test (Jones 1993). Multivariate normality assumption of errors was assessed by graphic methods. Comparisons between means were made by contrast examination. Statistical analyses were performed with the MIXED (SAS 1992) procedure of the SAS statistical package. In addition, UNIVARIATE (SAS 1990a) and GPLOT (SAS 1990b) procedures were used.

## Results

### Seasonal changes by scanning observations

A summary of the whole-year platform use for males and females was based on the scan sampling observation and presented as the percentage of observations when the fox was recorded to be on the platform (Figure 3). Whole-year median platform use for females averaged 27.0%, being significantly ( $p < 0.001$ ) higher than that of males (median 8.3%). Furthermore, platform use varied significantly ( $p < 0.001$ ) by month in both sexes. Platform use was lowest during January–March when the medians for males and females averaged 3.3% and 5.9%, respectively. After March, platform use increased markedly. Highest values were found in July, when the medians for males and females were 29.4% and 48.4%, respectively. During autumn, platform use continuously decreased. In December, the median for males was already zero, when in females it was still as high as 12.1%.

### Seasonal changes by video recordings

On average, females used platforms significantly ( $p < 0.001$ ) more (median 572 min/24 h) than males (median 317 min/24 h). Both the scan sampling data and the video recordings (Figure 3) indicated significant ( $p < 0.001$ ) seasonal variation in platform use. Highest values for both males (median 913 min/24 h) and females (median 872 min/24 h) were found in July. During February–April and November–December, median use for males approached zero. Lowest values for females were found in December (median 216 min/24 h).

### Function of platform use

The video recordings revealed platforms to be most frequently used for sleeping (medians of the year for males and females 309 and 543 min/24 h, respectively), followed by resting (medians 23 and 55 min/24 h) and jumping (medians 8 and 16 min/24 h). All three activities showed significant ( $p < 0.001$ ) seasonal variations (Figure 4). Females used platforms for all behaviours more than males with this difference being greatest for resting ( $p < 0.001$ ) and least for jumping ( $p < 0.05$ ).

### Circadian distribution of platform use

Platform use distribution for each hour of the day is summarized in Figure 5. The general pattern of the distribution was rather similar for both sexes. Platform use peaked between 4–5 a.m., and was lowest shortly after of farm work began at about 8–9 a.m. Use rose again at noon, reaching a third peak at 10–11 p.m.

Selected examples of the 24-h distribution for three different months are given in Figure 6. The examples represent extremes of the recorded distribution. Variation in the 24-h distribution between different months was smaller for females than males.

Korhonen, H. & Niemelä, P.: Seasonal changes in platform use by adult farmed silver foxes (*Vulpes vulpes*)

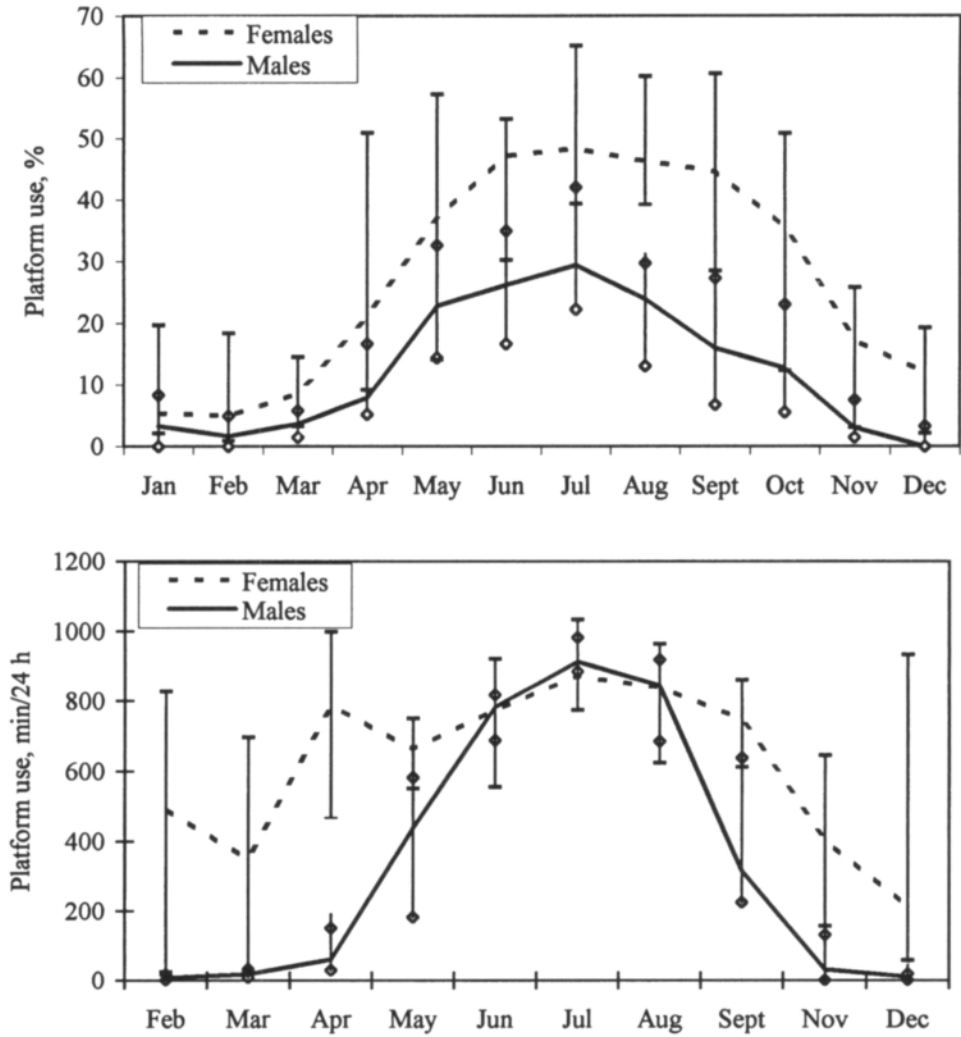
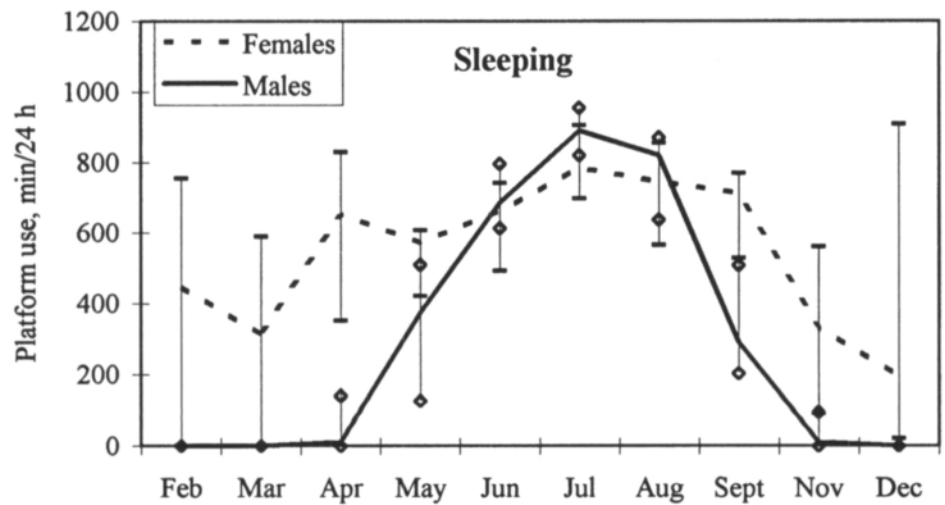
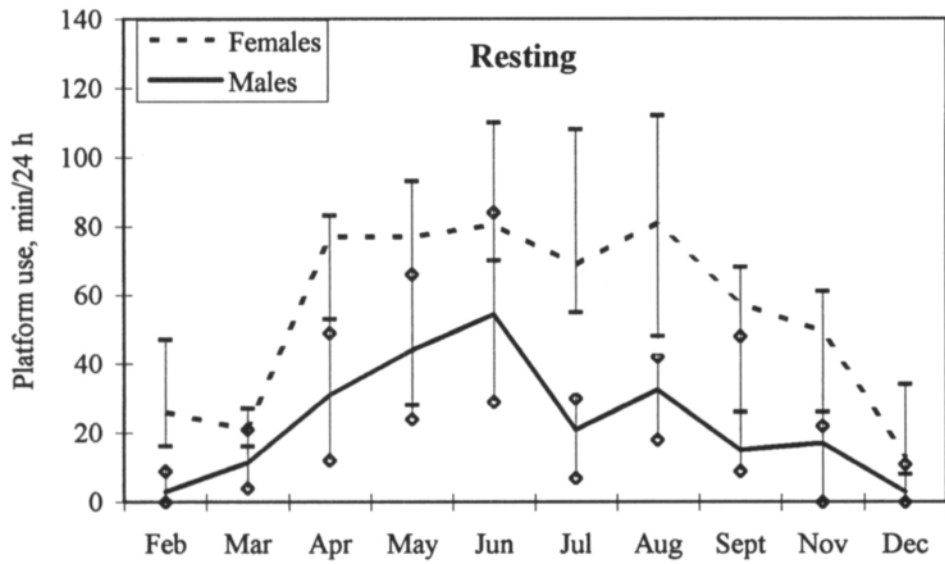
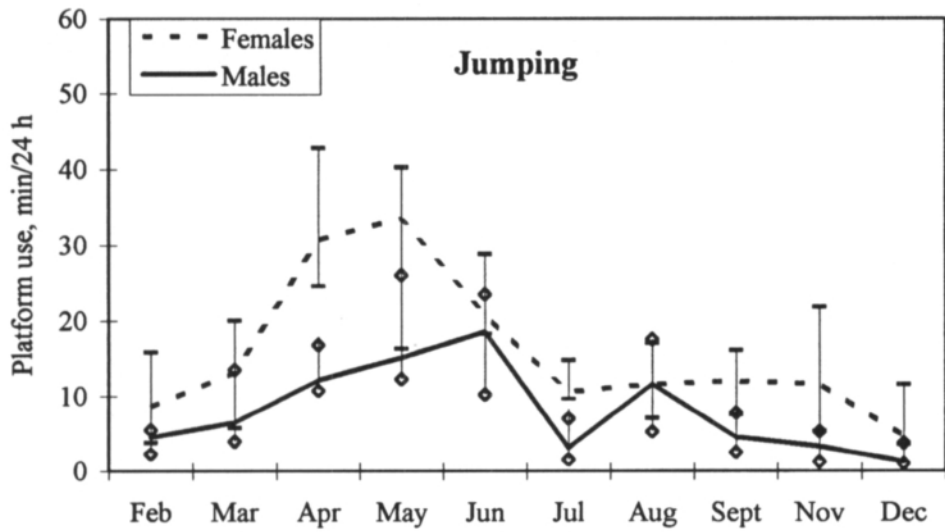

Fig. 3. Seasonal changes in platform use by adult silver foxes. Data are presented as medians with 1st and 3rd quartile intervals. Above: daytime scan sampling results expressed as the % of observations the fox was observed on the platform. N=28 males, N=28 females. Below: 24-h video recordings expressed as min/24 h the fox was seen on the platform. N=10 males, N=10 females. Note that data from Jan and Oct are missing because the recordings were then cancelled due to technical reasons (the same note concerns Figure 4 also).

Fig. 4. (see next page) Distribution of platform use for jumping, resting and sleeping (min/24 h). Data are presented as medians with 1st and 3rd quartile intervals, and are based on video recordings of the same animals as in Figure 3.



Korhonen, H. & Niemelä, P.: Seasonal changes in platform use by adult farmed silver foxes (*Vulpes vulpes*)

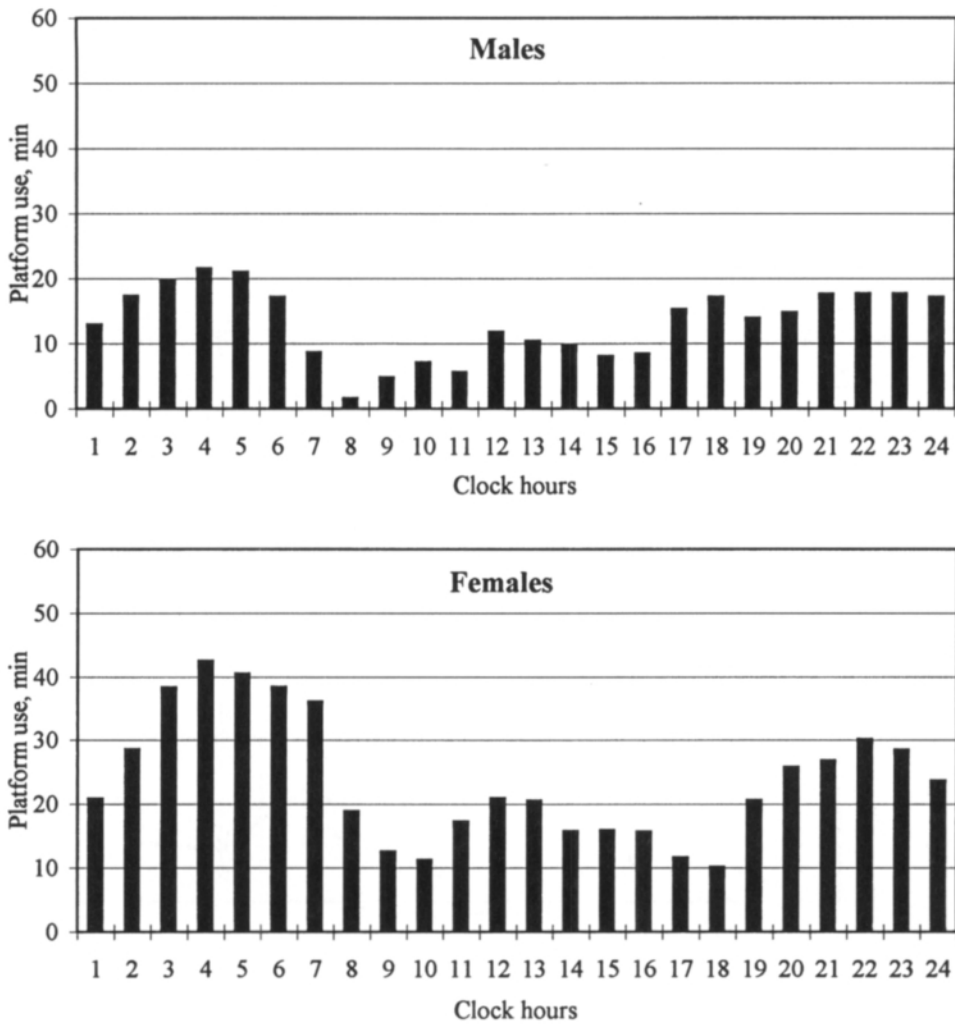

Fig. 5. Circadian distribution of platform use (min/h) of male and female silver foxes. In each study month, medians were calculated for each hour of the 24-h interval. Thereafter, the results of all study months were summarized.

## Discussion

Environmental enrichment entails the addition of environmental features or changes in their method of presentation which increase the complexity of a captive animal's environment (Hubrecht 1993). Enrichments are thought to result in beneficial effects on behaviour and other as-

pects of biological function (Newberry 1994). The European Convention (1991) has concluded that environmental enrichment of farmed foxes can be achieved by equipping cages with a whole-year nestbox or a platform. The present study clarified the role of platforms. The results showed that, on average, the test animals made adequate use of the whole-year platforms. However, the use peaked in summer, being slight in



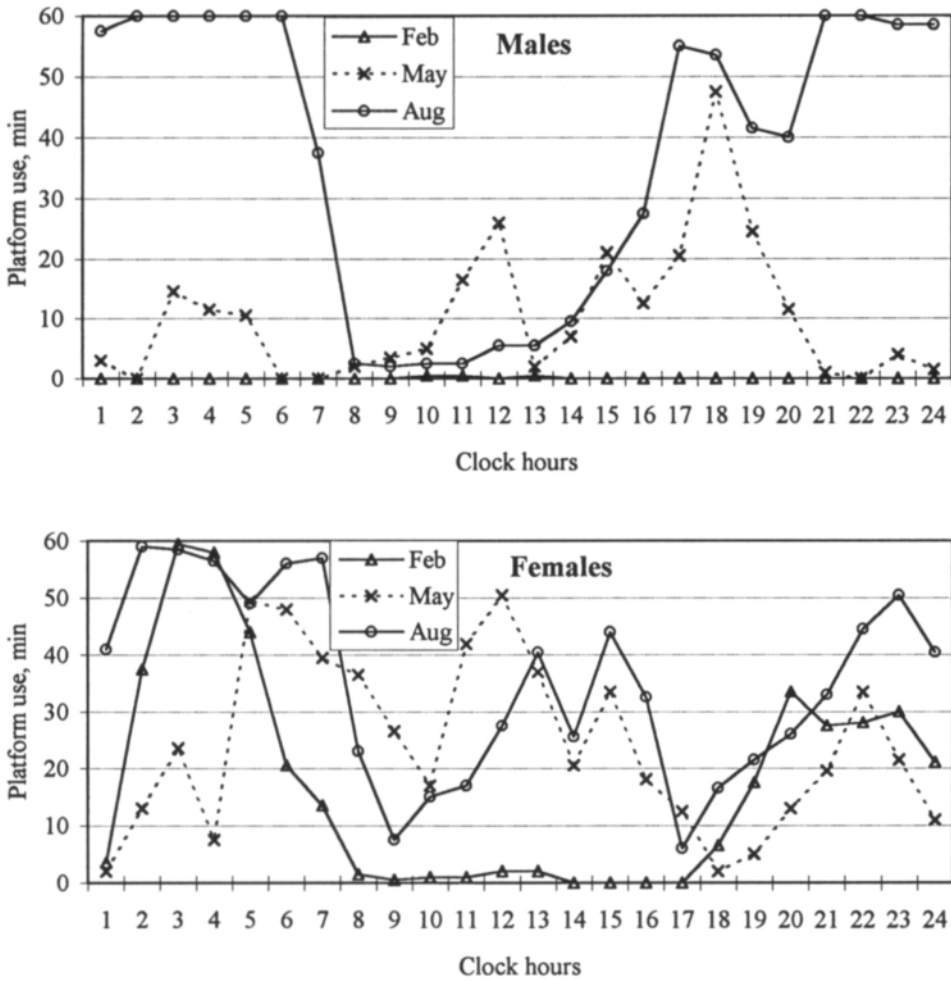

Fig. 6. Selected examples for circadian distribution of platform use (min/h) during three different months.

winter. It has recently been emphasized that frequency of platform use by farmed foxes does not necessarily reflect their need for such equipment only. According to Bakken et al. (1994), the fact that an animal knows that it has both a refuge and an observation platform can be of great importance to its well-being, even though the equipment might be used infrequently. In this respect, platforms such as those presently studied, could

be considered to enhance the welfare of farm-bred foxes. However, the problem is that no reliable way is available for measuring the potential use of a platform or any corresponding option. If an animal does not use an optional piece of equipment, two possible explanations may apply. First, the animal does not need it or, second, the animal uses it in potential situations. The relevance of the latter need cannot be meas-

*Korhonen, H. & Niemelä, P.: Seasonal changes in platform use by adult farmed silver foxes (Vulpes vulpes)*

ured, and is therefore only speculative as in the paper of Bakken et al. (1994).

The fact that captive animals display certain types of behaviour, even when such behaviour is not necessary for physiological reasons, has contributed to the concept of "ethological needs", implying that animals suffer if they are unable to express these behaviours (Jensen and Toates 1993). The recommendations of the European Convention (1991) suggest that the three main needs of the farmed fox, i.e. rest, observation and hiding would be satisfied by providing the animals with a whole-year shelter. The presently studied platform type appears to adequately meet at least the first two needs as activities of both long (sleeping) and short (resting, jumping) duration were encountered. Marked amounts of both short-term resting and sleeping by the test foxes can be interpreted to mean that the need for rest was fulfilled. Recent studies have demonstrated that sites offering a good view are preferred by foxes because they enable the animals to survey the environment (Harri et al. 1992, Mononen et al. 1993, 1995b, Korhonen and Niemelä 1995). One obvious function of jumping and short-term resting is that these activities allow the animal to observe its surroundings. Another reason why foxes often prefer to sleep on platforms may be due to the fact that if a disturbance were to occur, the animal would thus have a better possibility to observe and respond to it. The question as to what extent platforms may serve as a refuge is more complex, however. When a fox jumps onto a platform briefly or remains there for a longer period, can both or even one of these two activities be interpreted as hiding behaviour? Recent disturbance tests conducted on blue foxes (Korhonen and Niemelä 1995) have revealed that, during severe disturbances, foxes will jump onto a platform if one is available. The jumping response can obviously be considered as an attempt to escape, i.e. the fox seeks refuge on the platform. This suggests that platforms would partly fulfill the need for hiding also. However, the problem here is that when a fox jumps onto a platform as a result of disturbance, it is often rather difficult

to distinguish whether the reaction derives from a wish to observe or to hide. Therefore, nestboxes serve the fox better as hiding places (Harri et al. 1992), and if both pieces of equipment are simultaneously available, foxes prefer nestboxes (Pedersen and Jeppesen 1993).

The present results revealed that platform use by silver foxes varies seasonally, being highest in summer and lowest in winter. This conclusion was confirmed by the results of both daytime scanning observations and 24-h video recordings. The general pattern of seasonal variation was much like that observed in farmed blue foxes (Korhonen et al. 1996). Thus, the significant effect of season on platform use has been demonstrated in both farmed fox species. However, the fundamental explanation behind the extended seasonal variation in platform use observed remains an open question. It is known that seasonal changes in platform use coincide with some crucial changes in the farmed fox and its housing environment which perhaps directly or indirectly explain the observed variations. Firstly, environmental factors such as daylength and ambient air temperature have parallel changes with seasonal platform use (Figure 1). Secondly, body weight (Figure 1; Korhonen and Harri 1988) and fur insulation of the fox (Korhonen and Harri 1986) undergo regular yearly variations but in a reversed order, whereby these variables are lowest in summer and highest in winter.

Moreover, it has been found that the surface of wooden platforms become cold and freeze as winter approaches. Use of a cold substrate would thus increase the animal's heat loss significantly (Korhonen 1987). Effect of the cold surface is among the explanations speculated for decreased platform use during winter. In our previous year-round blue fox study (Korhonen et al. 1996) both wooden and wire-mesh materials were compared. Variations in platform use were encountered in both cases, but to a lesser extent in the latter. This finding suggests that the cold platform theory does not exclusively explain the observed seasonal variations. In addition, it has been suggested (Korhonen and Niemelä 1994) that the platform dimensions are too narrow to

provide foxes with enough space to assume the curled posture required for maximum winter fur insulation (Scholander et al. 1950), and therefore, they prefer to sleep on the cage floor. Furthermore, warmer temperatures during summer enable the animals to assume a more stretched out position on the platform. In fact, excessively high temperatures can be occasionally problematic in the summer, suggesting that foxes might prefer shady places such as platforms on which to cool off. This hypothesis requires further investigation, however. A third explanation for variations in platform use is that towards winter the animals become too heavy, making access onto the platforms less convenient (Mononen et al. 1993). However, this has been refuted in our previous blue fox experiments (Korhonen et al. 1996) in which test animals were implanted with melatonin capsules in summer to induce higher autumn body weight. Platform use by the melatonin-treated and control animals, however, was found to be quite similar despite the significant differences in body weights. Seasonal changes in photoperiod intensity are a fourth explanation. During the dark photoperiod in winter, observation from the platform might be difficult or unnecessary and foxes therefore remain on the cage floor. However, evidence for this hypothesis has not yet been demonstrated. In summary, it appears that the actual explanation for seasonal variations in platform use still remains open for further study.

A whole-year study on blue foxes revealed a tendency for platform use by females to exceed that of males (Korhonen et al. 1996). Consequently, in the present silver fox study the differences in platform use between sexes similarly revealed a greater use for females, but now it was significantly more pronounced. The same pattern of somewhat greater platform use by females has also been found in some previous short-term studies (Korhonen and Niemelä 1993, 1994, Korhonen et al. 1995). According to data from the present video recordings, females preferred to sleep and rest on platforms more than males did. A similar result was obtained in an earlier blue fox study (Korhonen et al. 1996).

Thus, sex-related differences in platform use between foxes can be explained by the fact that females sleep and rest on them more frequently. Furthermore, as Figure 4 clearly shows, during the whelping period females used the platforms significantly more for jumping than males did. A short-term activity such as jumping would enable females to intermittently scan their surroundings. The fact that females generally use platforms more often than males may have a biological basis in that kits are normally raised and guarded by females (Korhonen and Alasuutari 1994). Under farm conditions, females are occasionally seen emerging from the nestbox to recline or sleep on the nestbox roof. Such a pattern of preference for higher places might also be carried over outside the whelping season and thus persist in females provided with platforms but not nestboxes.

Results on the 24-h distribution of platform use showed that use varied around the clock in a repetitive pattern. This finding is in good agreement with our previous findings (Korhonen and Niemelä 1993, 1994, 1995). The fact that the activity of farmed silver foxes varies during each hour of the 24-h interval (Kaleta and Brzozowski 1985) obviously explains the observed differences in platform use. Furthermore, it has been found that the circadian activity profile of farmed animals differs from that of wild animals. Farmed animals display a looser relation to environmental conditions, adhering more to the activity rhythm of the farm staff (Klochov 1965). According to the present results, it appears clear that farm work activates the animals, and leads to an observable decrease in daytime platform use. During the night the most common behaviour of the farm foxes was sleeping for long periods and often on the platforms. This, of course, increased the total amount of platform use at night.

In conclusion, farmed silver foxes showed marked seasonal variations in platform use, with use being lowest in the winter and highest in the summer. The recommendations of the European Convention (1991) for farm foxes relating to such needs as rest, observation and hiding can

*Korhonen, H. & Niemelä, P.: Seasonal changes in platform use by adult farmed silver foxes (Vulpes vulpes)*

be fairly well satisfied by means of the presently studied platform type. Enhancement of animal welfare can be expected as the platforms increased both the complexity of the cage environment and behavioural repertoire of the animals studied.

*Acknowledgements.* Thanks are due to the staff of the research station for providing valuable assistance in carrying out these lengthy experiments. Particularly, Ms. Sanna Moisio is acknowledged for analysing the video tapes and Mr. Pekka Siirilä for computer assistance.

## References

- Bakken, M., Braastad, B.O., Harri, M., Jeppesen, L.L. & Pedersen, V.** 1994. Production conditions, behaviour and welfare of farm foxes. *Scientifur* 18: 233–248.
- Berg, H.** 1986. Rehutietoutta Turkiseläinkasvattajille. Turkiseläintutkimuksia 23. Suomen Turkiseläinten Kasvattajain Liitto ry. Vaasa, Painopinta ky. 99 p.
- Braastad, B.O.** 1992. Progress in the ethology of foxes and mink. *Norwegian Journal of Agricultural Science (Supplement)* 9: 487–504.
- European Convention** 1991. European Convention for the protection of animals kept for farming purposes. Strasbourg 1976, ETS 87. Recommendations Concerning Fur Animals, 25 June 1991. 19 p.
- Harri, M., Mononen, J., Korhonen, H. & Haapanen, K.** 1991. A study of the use of resting platforms by farmed blue foxes. *Applied Animal Behaviour Science* 30: 125–139.
- , **Mononen, J., Rekilä, T. & Korhonen, H.** 1992. Whole-year nest boxes and resting platforms for foxes. *Norwegian Journal of Agricultural Science (Supplement)* 9: 512–519.
- Hubrecht, R.C.** 1993. A comparison of social and environmental enrichment methods for laboratory housed dogs. *Applied Animal Behaviour Science* 37: 345–361.
- Jensen, P. & Toates, F.M.** 1993. Who needs “behavioural needs”? Motivational aspects of the needs of animals. *Applied Animal Behaviour Science* 37: 161–181.
- Jeppesen, L.L. & Pedersen, V.** 1990. Improvement of management routines and cage systems in fox production. *Scientifur* 14: 237–242.
- & **Pedersen, V.** 1991. Effects of whole-year nest boxes on cortisol, circulating leucocytes, exploration and agonistic behaviour in silver foxes (*Vulpes vulpes*). *Behavioural Processes* 25: 171–177.
- & **Pedersen, V.** 1992. Correlation between levels of cortisol, behaviour and nest box use in silver fox vixens. *Norwegian Journal of Agricultural Science (Supplement)* 9: 505–511.
- Jones, R.H.** 1993. Longitudinal Data with Serial Correlation: a State-space Approach. London, Chapman and Hall. 225 p.
- Kaleta, T. & Brzozowski, M.** 1985. The activity of farm silver fox (*Vulpes vulpes*) in summer. *Scientifur* 9: 179–180.
- Klochkov, D.** 1965. Circadian rhythm of minks belonging to different genotypes and their reaction to photoperiodic conditions. *Bulletin Soc. Nat. Moscou, Section Biology* 70: 106–112.
- Korhonen, H.** 1987. Significance of sleeping plate as a thermal protection for farmed raccoon dogs (*Nyctereutes procyonoides*). *Comparative Biochemistry & Physiology* 87A: 631–633.
- & **Alasuutari, S.** 1994. Social relationships and reproductive performance in group-living arctic blue foxes. *Agricultural Science in Finland* 3: 49–58.
- & **Harri, M.** 1986. Comparison of hair coat structure between the raccoon dog and blue fox. *Zeitschrift für Säugetierkunde* 51: 281–288.
- & **Harri, M.** 1988. Regulation of Energy Balance in Farmed Canids. In: Murphy, B.D. & Hunter, B.D. (eds.). *Biology, Pathology and Genetics of Fur Bearing Animals. Proceedings of the IV International Congress in Fur Animal Production.* 21–24 August 1988, Rexdale, Ontario, Canada. University of Saskatchewan press, Saskatoon. p. 344–350.
- , **Ketoja, E. & Niemelä, P.** 1995. Comparison of daytime use between platform types, materials, ceilings and experiences in juvenile blue foxes (*Alopex lagopus*). *Applied Animal Behaviour Science* 45: 125–138.
- & **Niemelä, P.** 1993. Use of resting platforms by growing blue foxes. *Scientifur* 17: 271–276.
- & **Niemelä, P.** 1994. Use of various platforms and nest-box by farmed blue and silver foxes. Resultater af de Senaste Års Nordisk Pelsdyrforskning, NJF-Seminar nr. 253. Rebild, Denmark 28–30 September 1994. p. 23.
- & **Niemelä, P.** 1995. Platform use by juvenile and adult silver foxes (*Vulpes vulpes*). *Scientifur* 19: 179–187.
- , **Niemelä, P. & Tuuri, H.** 1996. Seasonal changes in platform use by farmed blue foxes (*Alopex lagopus*). *Applied Animal Behaviour Science* (in press).
- Mononen, J., Harri, M., Rouvinen, K. & Niemelä, P.** 1993. The use of resting platforms by young silver foxes (*Vulpes vulpes*). *Applied Animal Behaviour Science* 38: 301–310.
- , **Harri, M., Rekilä, T. & Ahola, L.** 1995a. Foxes do not like nontransparent walls. Resultater av de Senaste Års Pelsdjurforskning, NJF-Seminar, Göteborg, Sverige, 4–6 October 1995, 1 p.
- , **Harri, M., Rekilä, T., Korhonen, H. & Niemelä, P.** 1995b. Use of nest boxes by young farmed silver foxes (*Vulpes vulpes*) in autumn. *Applied Animal Behaviour Science* 43: 213–221.

**Newberry, C.** 1994. Environmental enrichment: bringing nature to captivity. 28th International Congress of the ISAE, Research Centre Foulum, Denmark, 3–6 August 1994, p. 51–67.

**Pedersen, V. & Jeppesen, L.L.** 1993. Daytime use of various types of whole-year shelters in farmed silver foxes (*Vulpes vulpes*) and blue foxes (*Alopex lagopus*). Applied Animal Behaviour Science 36: 259–273.

**SAS** 1990a. SAS Procedures Guide, Version 6, Third Edition. SAS Institute Inc., Cary, NC. 705 p.

**SAS** 1990b. SAS/GRAPH Software: Reference, Version 6, First Edition, Volume 2, SAS Institute Inc., Cary, NC, 1342 p.

**SAS** 1992. SAS Technical Report p-229, SAS/STAT Software: Changes and Enhancements. release 6.07. SAS Institute Inc., Cary, NC, 620 p.

**Scholander, P.F., Hock, R., Walters, V. & Irving, L.** 1950. Adaptation to cold in Arctic and tropical mammals and birds in relation to body temperature, insulation and basal metabolic rate. Biological Bulletin 99: 259–271.

## SELOSTUS

### Aikuisten hopeakettujen hyllynkäytön vuodenaikaisvaihtelut

Hannu Korhonen ja Paavo Niemelä

*Maatalouden tutkimuskeskus*

Tutkimuksessa selvitettiin, missä määrin aikuisten hopeakettujen (*Vulpes vulpes*) hyllynkäyttö vaihtelee vuodenajoin. Hyllynkäyttöä mitattiin videokameralaitteiston ja otoshavainnoinnin avulla. Tulokset osoittivat, että aikuiset hopeaketut käyttävät hyllyjä vähiten talvella ja eniten kesällä ( $p < 0,001$ ). Naaraat käyttävät hyllyjä enemmän kuin urokset ( $p < 0,001$ ). Hyllynkäytössä on selvää vuorokautista vaihtelua sekä uroksilla että naarailla. Käyttö on korkeinta yö-

lä (klo 4–5) ja vähäisintä aamulla heti tarhatöiden alettua (klo 8–9). Hopeaketut käyttivät hyllyjä eniten nukkumiseen ja vähiten hyppeleyn. Tutkittu puinen U-hyllymalli täyttää melko hyvin Euroopan neuvoston määräysten (1991) mukaiset kettujen etologiset tarpeet eli tarjoaa paikan tarkkailua ja lepoa varten. Tulosten perusteella voidaan tutkittua hyllymallia suosittelua kettutarhojen käyttöön.