

Tekniikan Waiheita
ISSN 2490-0443
Tekniikan Historian Seura ry.
39. vuosikerta: 1
2021
<https://journal.fi/tekniikanwaiheita>



Innovation in preservation: Floating Pneumatic Grain Elevator "Stadsgraanzuiger 19"

Richard Velthuizen

Rotterdam Centre for Modern Maritime History,
Erasmus University Rotterdam / Maritime Museum Rotterdam
Stichting Rotterdamse Graanelevator
 <https://orcid.org/0000-0002-8903-5298>

To cite this article: Richard Velthuizen, "Innovation in preservatio: Floating Pneumatic Grain Elevator 'Stadsgraanzuiger 19'" Tekniikan Waiheita 39, no. 1 (2021): 7-30. <https://doi.org/10.33355/tw.103101>

To link to this article: <https://doi.org/10.33355/tw.103101>

Innovation in preservation: Floating Pneumatic Grain Elevator “Stadsgraanzuiger 19”

Richard Velthuizen¹

The preservation of a large and complex museum vessel is often demanding work in building good practices and beneficial networks among specialists, supporters, and the community. The grain elevator “Stadsgraanzuiger 19” that can be visited either at Maritime Museum Rotterdam or Museum aan de Stroom in Antwerp is a case in point. It’s story exemplifies that challenges in museum collections and research work to permanently preserve such a spectacular and massive machine. In this article Richard Velthuizen revisits the history of grain elevators, the socio-technical change at Rotterdam port, and the preservation and cultural heritage efforts in saving this historic elevator. He also unentangles the social process with which the large, floating machine has been preserved.

Introduction

From the early twentieth century until the mid-1980s, pneumatic floating grain elevators have been used in the transshipment of grain and other agrarian bulk products in the port of Rotterdam. Replacing manual labour, the introduction of the machines was perceived as a threat to the livelihood of local dock workers, who tried to mitigate their positions through massive strikes.² To no avail, rationalisation and industrialisation went onwards, resulting in dozens of floating grain elevators working in Rotterdam and many other European ports. After 1985, new transshipment technology made the grain elevators obsolete at their turn. Once dominating the European port skylines, nowadays the grain elevators are all gone. Except for one. The port of Rotterdam is home to the only floating grain elevator left worldwide, “Stadsgraanzuiger 19”. A team of dedicated volunteers not only cared for its maintenance, but also fully restored its operational capability.³ Its preservation was accompanied by a series of challenges, which continue until present day.

¹ Richard Velthuizen studies the history of Dutch shipbuilding after 1983 at the Erasmus Centre for Modern Maritime Studies, a cooperation between Erasmus University Rotterdam and the Maritime Museum Rotterdam, and is involved in Stichting Rottedamse Graanelevator, which together with the Maritime Museum Rotterdam and Museum aan de Stroom in Antwerp preserves and restores the last remaining floating pneumatic grain elevator “Stadsgraanzuiger 19”

² On the introduction of grain elevators in Rotterdam and the resulting protests: D. van Lente, “Machines and the Order of the Harbour: The Debate About the Introduction of Grain Unloaders in Rotterdam, 1905-1907”, in: *International Review of Social History*, No. 43 (1998) 79-109; H. van Driel, J. Schot, “Radical Innovation as a Multilevel Process: Introducing Floating Grain Elevators in the Port of Rotterdam”, in: *Technology and Culture* 46, no.1 (2005) 51-76; E.J. Smit, *De syndicale onderstroom: Stakingen in de Rotterdamse haven, 1889-2010* (Amsterdam, 2013) 53-83; H. van Driel, J.W. Schot, “Het ontstaan van een gemechaniseerde mas-sagoedhaven in Rotterdam”, in: H.W. Lintsen, J.W. Schot (eds.) *Techniek in Nederland in de twintigste eeuw. Deel 5. Transport, communicatie* (Zutphen, 2002) 75-96; H. van Driel, J. Schot, “Regime-transformatie in de Rotterdamse graanoverslag”, in: Nederlands Economisch Historisch Archief, G. Devos (ed.) *NEHA-Jaarboek 64* (Amsterdam, 2001) 266-317; C.A. Chocheret, *Het elevator-bedrijf in de Rotterdamse haven* (Rotterdam, 1933); P. Janse, K. van den Ende, “Stadsgraanzuiger 19”, in: *Scheepshistorie* 13 (Ede, 2012) 98-115.

³ <http://www.elevator19.nl/> (01-10-2020).



Image 1. Stadsgraanzuiger 19 in the Leuve Harbour, Rotterdam. Source: Maritime Museum Rotterdam. Photo: T. de Man.

In the next paragraphs, the history of Stadsgraanzuiger 19 will be outlined. It will become clear how the preservation of a unique object in maritime heritage demanded the efforts of individuals, foundations, trusts, (local) governments, companies, museums, and researchers. These efforts proved to be successful in preserving the last specimen of a generation of machines once indispensable in European ports, thereby turning a mere machine into a museum object. Will new and innovative endeavours instigated to preserve the last of the Mohicans for future generations also prove viable?

A giant vacuum cleaner

Until 1860, Rotterdam was much like any other small Dutch harbour city. Located on the northern shores of the New Maas River, storage and transshipment of commodities of all sorts accounted for a large part of the city's economy. No longer in use today, downtown port basins called the "Wine Harbour", "Beer Harbour" and "Ship makers' Harbour" remind us of the city's maritime past. The harbours are connected to one of the oldest port basins in Rotterdam, the Leuve Harbour. Built in 1608, it functioned as a connection with the open river, the New Maas, in which various embranchments of the Rhine River delta are

merging. In the present, the Leuve Harbour is home to a collection of historical ships and other maritime heritage curated by the Maritime Museum Rotterdam. Between the steam powered tugs, historical cranes and ancient sailing ships towers a thirty meters high machine built on a floating barge, in popular vernacular also called a “Spiders head”. With long dangling suction tubes resembling a spiders segmented legs, the steam powered pneumatic grain elevator “Stadsgraanzuiger 19” (City grain elevator 19) leaves tourists wondering what it exactly might be.

Museum tour guides tell the tourists that “The 19” works like a giant vacuum cleaner. It represents a period of major transformations in transshipment methods, and thereby the growth and infrastructure in the history of the Port of Rotterdam and many other ports in Europe. It also represents the start of the replacement of many traditional port related jobs by new costs- and labour-saving technology.⁴ Floating grain elevators have been deployed in the ports of Amsterdam, Antwerp, London, Liverpool, and Hamburg.⁵ In all ports the elevators were introduced in the first decades of the twentieth century. They also disappeared everywhere during the 1980s. Although the overall design of elevators in various European ports was the same, variations in details made no elevator appeared exactly the same.

The growth of grain trade in Rotterdam

Before 1870, shifting sand beds in the bottom of the Rhine River Delta caused a lot of problems for inland going ships by irregularly blocking the open sea access to Rotterdam. Water currents were unpredictable, which caused unreliable routes from sea to inland port cities. Not seldomly ships were grounded on suddenly shifting sand beds below the water surface, causing loss of time, or even damaging the ship or its cargo. To circumvent these problems, plans were made to create a direct connection between Rotterdam and open seawater in 1863 by digging through the dunes at the nearest coastline. In 1872, the project was finished and the New Waterway was opened, providing a safer and easier access to Rotterdam.⁶ Together with major improvements in the Rhine River shores inlands and the phenomenal blossoming of German trade and industry, these technical ingenuities paved the way for Rotterdam to grow as a port city.⁷ New port basins were soon dug out near the old ports in the city’s centre, from 1880 onwards increasingly growing in size and expanding further outwards.⁸ Furthermore, on the southern shores of the New Maas river, housing was developed for the increasing port workforce moving in from the hinterlands. Nowadays, some of the inner-city port basins are partly filled up again to accommodate city developments. Others got functions assigned in the city’s cultural life, adding to the revered connection between Rotterdam and its maritime history. Built around the 1900s, larger basins as the Maas- Rijn- and Waal Harbours -all named after rivers in the Rhine delta- still possess a maritime function in the present, and define a large part of the city’s

⁴ <https://www.maritiemmuseum.nl/tentoonstellingen/graanelevator> (01-10-2020).

⁵ <http://dingler.culture.hu-berlin.de/article/pj329/ar329037> (01-10-2020).

⁶ Van Driel & Schot, “Het ontstaan van een gemechaniseerde massagoedhaven”, 79.

⁷ Van Lente, “Machines and the Order of the Harbour”, 81.

⁸ Ibidem.

infrastructure. Today, with its 310 hectares the Waal Harbour still holds the position of the largest inland graven port basin worldwide.⁹

The Rijn Harbour and especially the Maas Harbour facilitated grain and other dry agrarian bulk products hauling and storage. Before the mechanisation by new technologies powered by steam, grain transshipment consisted mainly of manual labour, which was abundantly available through the influx of workers from the hinterland. Dry bulk cargo ships moored at the Rijn or Maas Harbour docks to be unloaded in a process that has been described as “observing an ant hill”.¹⁰ An average dry bulk ship of 6000 gross tonnes provided a week’s labour for approximately 125 people. After mooring the ship, trimmers went down the ship’s hull, scooping up the grain with shovels and baskets in large bags. After filling, the bags were stitched by sewers, and carried to the main deck, where weighers determined and tallied the weight. Other dock workers consequently carried the 80-100-kilogram loads on their backs to the jetty over ladders and gangways. The bags could be stored temporarily, or be directly transported to its clients by trains, inland ships, or lorries. Of course, middle- and upper management supervisors, representing both clients and grain traders, had to oversee the whole process.¹¹ During the unloading process, weather conditions were closely monitored. When rain started, the ant hill came to a stop; to protect the perishable products from moisture, ships’ hatches were closed, and work was suspended until the weather improved.

In 1899, the first modern grain storage facility in Rotterdam was erected at the Rijn Harbour wharf by the Amsterdam based company *Het Nederlandsche Veem* (The Dutch Warehouse Company), which was appropriately called “The Firstling”.¹² To improve product handling, the Firstling was equipped with a steam powered bucket elevator, able to scoop up bulk products from ships. After automated weighing, the product was mechanically transported into the storage facility. The bucket elevators were the first industrial replacement for manual transport, even though the heavy machinery was difficult to operate and created a lot of dust bothering the dock workers working with it.¹³

The introduction of elevators in Rotterdam

Around 1900, approximately 2000 workers found employment in the grain handling industry in Rotterdam.¹⁴ The working conditions were harsh; the hard manual labour took a heavy toll on the body, and working hours were long and often irregular. Dock workers were recruited on a daily basis, and were not formally organised yet, so labour union representation was absent. Wages were low, and when work was not available, there was no income at all.¹⁵ Structural poverty resulting in empty stomachs encouraged theft, which local authorities

⁹ Van Driel & Schot, “Het ontstaan van een gemechaniseerde massagoedhaven”, 79.

¹⁰ Smit, “De syndicale onderstroom”, 57; Van Driel & Schot, “Het ontstaan van een gemechaniseerde massagoedhaven”, 89. Van Lente, “Machines and the Order of the Harbour”, 83.

¹¹ Van Lente, “Machines and the Order of the Harbour”, 83.

¹² D.L. Uyttenboogaart, “Het graantransportbedrijf”, in: *Gedenkboek Rotterdam 1328-1928* (Rotterdam, 1928) 281.

¹³ Van Driel & Schot, “Het ontstaan van een gemechaniseerde massagoedhaven”, 89-90.

¹⁴ Van Lente, “Machines and the Order of the Harbour”, 83.

¹⁵ Van Driel & Schot, “Het ontstaan van een gemechaniseerde massagoedhaven”, 78.

Image 2. Design and working principles of a floating grain elevator. Source: Archive Stichting Rotterdamse Graanelevator.

tried to prevent by opening a special police department in the Rotterdam port area. Notwithstanding the harsh conditions, in a time with scarce or no social government provisions, any work meant that hungry mouths were filled and due rents were paid. Keeping in mind that 2000 families were maintained by the Rotterdam grain trade underscores the significance for the city's economy.

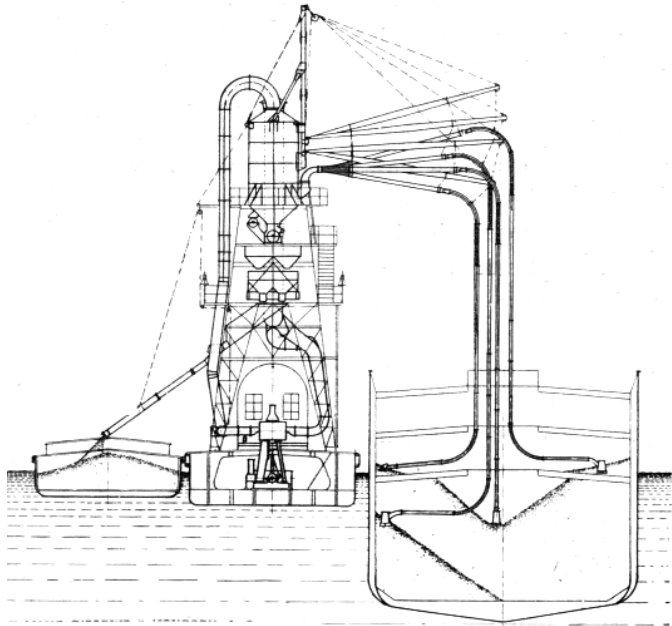

Concomitantly, the German Ruhr Area, the economical hinterland for the port of Rotterdam, was industrialising at an increasing pace. By implementing the newest technology, grain mills in Germany were able to increase capacity and processing speed. In 1901, a delegation of contractors, the *Verein Deutscher Handelsmüller* (German Mills Trade Organisation) visited the Rotterdam port area, representing the German millers and presumably also German machine builders.¹⁶ In their briefcases they carried the blueprints of an invention made in England. Over there, engineer F.E. Duckham had equipped the London based grain storage facility *The Millwall Docks* with a floating grain elevator that generated pneumatic induced suction induced by steam power.¹⁷ In 1896, Duckham had sold the patent to the German machine builder *G. Luther A.G.* in Brunswick.¹⁸ After much experimentation the concept had been improved and was already implemented in the ports of Hamburg and Bremen.¹⁹ The delegation tried to convince various stevedoring parties in the Rotterdam grain trade to consider modernisation in transportation according to the most modern technological standards. Trying to increase competitive pressure, the German representatives stated that some machines had already been sold in Emden, and negotiations with the port of Antwerp were pending.²⁰

¹⁶ Janse, Van den Ende, "Stadsgraanzuiger 19", 102. Van Driel & Schot, "Het ontstaan van een gemechaniseerde massagoedhaven", 90.

¹⁷ <https://www.british-history.ac.uk/survey-london/vols43-4/pp356-374> (01-10-2020).

¹⁸ <http://dingler.culture.hu-berlin.de/article/pj325/ar325001> (01-10-2020).

¹⁹ Cocheret, "Het elevator-bedrijf", 11.

²⁰ Idem 15.

The delegation argued that modern unloading techniques could reduce unloading time by 50 percent. Moreover, the suction tubes could be led into small openings on ship decks, so that large hatches could remain closed, providing for an advantage in bad weather conditions.²¹ In addition, the product flow would be completely sealed and secured. After the grain entered the suction tubes, it was weighed automatically, and directly transported to adjacent ships or to storage facilities. Securing the entire transportation process meant that the risks for mistakes, corruption in weighing, and for theft by hungry workers were reduced to a minimum. Additionally, working with these machines would eliminate the dependency on a loosely knit together army of workers, to be replaced by a small number of well-educated operators.²² Lastly, the grain would be cleansed in the process of unloading, because grain harvesting in the early twentieth century produced a lot of unwanted by-products. Chaff, weeds, halm leftovers and dirt all found their way into the cargo, adding to the overall weight. Mechanically removing waste made sure only pure grain would cross the German border, thereby reducing the risk of paying taxes for non-usable derivatives and waste. Not coincidentally the delegations most pressing argument was found in the cleansing of the grain, because at the very moment of advertising the elevators the German government had planned for a significant increase on grain import taxes in 1906.²³ This was of great concern for the German millers.

Notwithstanding the convincing arguments, the Rotterdam based stevedoring parties were initially not very interested in the German machines. The commonly shared fear was that irregularities in grain supply would interrupt a full continuous operation of the elevators, endangering their profitability.²⁴ Moreover, the introduction of the bucket elevators in the port of Rotterdam had met initial resistance from the grain workers, causing fear for further unrest if the pneumatic elevators would be introduced. Related to this objection, it would be proven that the concerns were painfully accurate. Another objection of the stevedoring companies was their routine that in times of high supply but low demand, the bulk ships themselves were used by the stevedores as a means of storage, to avoid storage costs on shore.²⁵ Lastly, none of the stevedoring companies in Rotterdam was prepared to take on the risk of such a capital-intensive investment. Consisting of an amalgam of small companies who were mutually competing, none of the individual parties dared to invest in a machine that bore so many risks. So, the stevedoring companies thanked the Germans kindly, but declined their proposals. They suggested the delegation to try their luck at the new facility of *Het Nederlandsche Veem*.²⁶

The manager of *Het Nederlandse Veem* in Rotterdam, J.C. Smalt, was exceptionally well known in the grain trading business. In contrast to his competitors, he responded with great enthusiasm to the plans of the delegation. However, Smalt also understood the risks of investment mentioned by the stevedoring companies. Therefore, he tried to convince the Amsterdam based board of *Het Nederlandsche Veem* to invest in Rotterdam and the machines. The board declined because the Germans were primarily interested in promulgating modernisations in Rotterdam. Fully convinced of the opportunity the elevators might

²¹ Idem, 12.

²² Idem 13; A. Voogd, *De graanelevators en de gisting in het havenbedrijf te Rotterdam* (Rotterdam, 1907) 5–6.

²³ Voogd, “De graanelevators en de gisting in het havenbedrijf”, 11.

²⁴ Cocheret, “Het elevator-bedrijf”, 15.

²⁵ Janse, Van den Ende, “Stadsgraanzuiger 19”, 103.

²⁶ Cocheret, “Het elevator-bedrijf”, 11.

provide, Smalt started a series of negotiations on his own. A slow and long process of lobbying with the initially sceptical stevedoring companies, workers representatives, venture capitalists and German machine builders, resulted in 1904 in a joined *Maatschappij tot Exploitatie van Drijvende Elevatoren* (Holding for the Exploitation of Floating Elevators. Hence: Elevator Holding).²⁷ Together the cooperative holding was able to raise enough capital to purchase two floating pneumatic elevators. In July 1905, the first bulk ship was unloaded by floating elevators.

Smalt's activities in creating a partnership for the purchase of the elevators did not go unnoticed by the 2000 grain workers. Even before the foundation of the Elevator Holding was announced, hot public debates about the plans arose in the press and on the streets of Rotterdam.²⁸ Especially the group of weighers was overrepresented amongst the protesters. In contrast to the port's army of day laborers, weighers were contracted middle class craftsman who were officially sworn in as civil servants. It was this group that feared the most for their jobs because of the automated weighing process on board on the elevators. From 1905 onwards, stirred by the sight of the two newly purchased elevators, strikes broke out, trickling down to other worker groups in the grain trade. Not long after, labourers from other trades in the port of Rotterdam joined, recognizing mechanisation as a general threat to their livelihoods.²⁹ As mentioned, it took 125 grain workers a full week to unload an average ship of 6000 Gross tonnes. Now two elevators, both with a crew of just ten to fourteen operators did the same amount of work in just two days. This meant a revolutionary reduction of the labour needed by 94 percent, numbers far higher than the German delegation had outlined in their presentations. The new machines were depicted as "bread robbers",³⁰ starting a modernisation process that threatened not only jobs in grain trade, but also every segment of port labour. The years 1905–1907 were characterized by several wild strikes, intense public debate, and civil unrest. After severe riots in 1907, the situation culminated in a request by the city council to the Dutch Navy to put a state of martial law on the Rotterdam port area.³¹

Notwithstanding civil unrest, protests and even sabotage, the investors cooperating in the Elevator Holding desired profits.³² Although confronted with a series of technical setbacks, the two elevators increasingly proved their success to the investors, other stevedoring companies, ship owners and grain traders. The workers had lost the struggle for public opinion about the introduction of the new elevators, in favour of the Elevator Holding. Additionally, increasingly the involved parties realised that the implementation of elevators in other European ports would result in a competitive disadvantage for Rotterdam. In 1908, under the guidance of Smalt, the cooperative holding of private investors was transformed into the *GEM - Graan Elevator Maatschappij* (Grain Elevator Company). The GEM grew to be the leading grain trade company in the Rotterdam Port area for the decades to

²⁷ Idem, 21.

²⁸ Cocheret, "Het elevator-bedrijf", 23.

²⁹ Smit, "De Syndicale onderstroom", 67.

³⁰ Van Lente, "Machines and the Order of the Harbour", 79; GEM, *De Does. Jubileumuitgave 75 jaar GEM* (Rotterdam, 1983) 10.

³¹ On the strikes and its implications: Van Lente, "Machines and the Order of the Harbour" 79–109.

³² Uyttenboogaart, "Het graantransportbedrijf", 289.

come. Immediately after it was founded, it purchased eight more floating elevators. In 1911, twenty GEM owned elevators were operational in the Rotterdam Maas- and Rijn Harbours.

Most of the grain workers who participated in the protests of 1905–1907, later benefited from the increasing volume of grain trade made possible by the elevators and found employ at the GEM. In 1910, the *Grain Silo Company* was founded, and built a storage facility which in the newspapers was called “The Giant of the Maas Harbour”.³³ Until 1985, the floating grain elevators were a landmark in the city of Rotterdam. After 1985 however, the floating elevators went as quickly as they came, made obsolete by suction installations with a capacity of 1000 tonnes per hour, or large cranes able to scoop up to 45M³ in a single hoist. In 1991, the GEM fused with other major companies in dry bulk product transshipment into European Bulk Services (EBS), presently still a major player in bulk product handling and storage in the Rotterdam Port area.³⁴

The floating grain elevator: how it works

The floating pneumatic elevator was a tower with a suction installation built on a barge. Antwerp’s city council ordered the 19th elevator of its fleet on the second of August 1926 at shipyard *Chantal Naval John Cockerill*, in the adjacent Hoboken, Belgium.³⁵ The steam engine, built by the German Luther A.G. (*Aktien Gesellschaft*), was placed inside a barge built on the shipyard. The barge itself measured 10,45 x 30 x 3,3 meters, with a depth of 2 meters below the water line. The skin, iron plates riveted on a framework of iron H-shaped beams, was 9 millimetres thick. In the middle section of the barge reinforcements were constructed to support the heavy steam engine. The boiler, in which the steam was generated by coal fire, was fabricated by Cockerill’s establishment in Seraing, Belgium.³⁶ The machine transported grain through suction tubes, which were lowered into the cargo space of a bulk carrier, directly into inland vessels waiting nearby. Besides grain, the elevators were also equipped to process other forms of dry bulk, such as seeds, cacao, soybeans, peanuts, or copra (dried coconut flesh used to produce soap).

Belowdecks, the space was divided into sections. The middle section consisted of two compartments uneven in size. The smaller compartment housed the boiler, the larger housed a vertical compound steam engine, which generated a thrust of 275 horsepower at 110 rotations per minute. The engine was propelled by two cylinders, one high pressure cylinder with a diameter of 460 millimetres, one low pressure cylinders with a diameter of 760 millimetres, both generating an equal amount of force through a flow of steam that loses its expanding pressure while being processed. The cylinders moved two drivers in an up- and downwards motion, which was converted into a rotating motion by a crankshaft belowdecks. On both ends of the crankshaft, additional drivers were connected to the two cylindrical vacuum pumps that were placed on deck level, with a diameter of 1310 millimetres. The two vacuum pumps were used to create a near vacuum low pressure in the upper compartments of the

³³ GEM, “De Does”, (Rotterdam, 1983)15.

³⁴ [https://www.ebsbulk.nl/over-ons/geschiedenis/\(01-10-2020\)](https://www.ebsbulk.nl/over-ons/geschiedenis/(01-10-2020)).

³⁵ Janse, Van den Ende, “Stadsgraanzuiger 19”, 105.

³⁶ Agentschap Onroerend Erfgoed 2020: Stadsgraanzuiger 19 [https://id.erfgoed.net/erfgoedobjecten/305804\(01-10-2020\)](https://id.erfgoed.net/erfgoedobjecten/305804(01-10-2020)).

Image 3. Technical details of a floating grain elevator. Source: Archive Stichting Rotterdamse Graanelevator.

machine, the recipient. The low pressure in the recipient consequently was used to create an upwards stream of air in the connected suction tubes, by which the products could be sucked up.³⁷ At full power, one elevator had a capacity of a maximum of a 200 metric tons per hour of cargo transhipment.³⁸

The unloading process started with the positioning of the suction tubes above the cargo. Hanging from

opposable arms, the suction tubes could be positioned by cable windlasses. After the cargo entered the recipient, the grain was separated from the air flow by a set of canvas filters, through which the grain fell into a rotating airlock. This made sure that the low pressure in the recipient remained intact. Once the product passed the airlock it was collected in the upper bunker. Shutters in the upper bunker floor could be opened and closed manually by the weigher operating the bascule scale in the weighing room. Once the shutters were opened by the weigher, the grain would fall into a collector attached to the bascule scale, which could contain up to three metric tonnes. The weigher would open the hatch in the bottom of the collector when the desired weight was reached, unloading the grain into the exit bunker and into a moveable pipe. The grain would then fall into the adjacent ship, ready for further transportation. Within the pipe a valve was made, operated by deck personnel, rendering the distribution of the cargo controlled and safe.³⁹

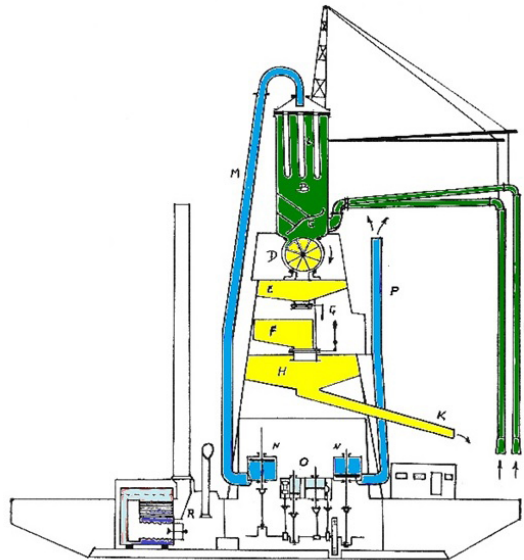

- | | | |
|-------------------|-------------------|---------------------|
| A: Suction tubes | F: Bascule scale | M: Air suction pipe |
| B: Recipient | G: Weighing room | N: Vacuum pumps |
| C: Catching plate | H: Lower bunker | O: Steam engine |
| D: Airlock | K: Unloading tube | P: Air exhaust pipe |
| E: Upper bunker | L: Dust filters | R: Boiler |

³⁷ Agentschap Onroerend Erfgoed 2020: Stadsgraanzuiger 19 <https://id.erfgoed.net/erfgoedobjecten/305804> (01-10-2020).

³⁸ Agentschap Onroerend Erfgoed 2020: Stadsgraanzuiger 19 <https://id.erfgoed.net/erfgoedobjecten/305804> (01-10-2020).

³⁹ For a detailed technical description on the operation of elevators, see: Janse, Van den Ende, "Stadsgraanzuiger 19", 109–113; K. de Vriese, *De vlottende graanzuiger* (Antwerpen, 2018) 15–18. See also: Agentschap Onroerend Erfgoed 2020: Stadsgraanzuiger 19 <https://id.erfgoed.net/erfgoedobjecten/305804> (01-10-2020), or: <http://www.machinemuseum.nl/graanzuiger.html> (01-10-2020); or: <http://www.elevator19.nl/pagina6.html> (01-10-2020). This section is a summary of information provided on these websites and articles.

The compartment belowdecks on the front side of the elevator was used as crew quarters. An elevator could be operated by a crew of eight to twelve men, depending on the cargo handled and the cargo ship's conditions. In the engine room, the machinist was responsible for operating and maintaining the steam engine, often aided by a second machinist, also known as *oil man*. Both were responsible for the lubrication of the hundreds of moving casted iron machine parts and the adjustments in the crankshaft's rotations regulating the required suction power. When the system got blocked by sucking up some unwanted items such as cargo separation materials, adjustments had to be made quickly. Also, for the workers at the end of the suction tubes in the bulk carrier's hull, a covert way to organize an extra small break for a cigarette was to let a burlap sack be sucked up "accidentally", which had to be removed from the tubes manually.⁴⁰

In the adjacent boiler room, one or two stokers controlled the fire used to create steam for the engine propelling the vacuum pumps. Coal was delivered in briskets of ten kilograms, which had to be broken down and distributed in the fire. Ashes had to be removed and the boiler pressure carefully monitored. Coal storage had to be administrated, and the system of valves connecting the various steam pipes that powered additional working material to the boiler had to be operated. As mentioned above, the tube driver operated the suction tubes from the operator booth on the third level. He also had to supervise the process of adding or removing extensions on the tubes, because the draught of a bulk carrier changes when the cargo is removed. In the meantime, one level lower, the weigher operated the bascule scale and carefully registered each weighing under the supervision of buyers and sellers' representatives, who carefully monitored the work. On deck level, deckhands guided the unloading process, operated the suction tube windlasses, and regulated the winches that were used to manoeuvre the elevator alongside the ship. Grain elevators did not have a propulsion engine on their own, the steam engine in the engine room's only purpose was to power transshipment related machinery onboard. By connecting steel cables to the bollards on the bulk carrier, the elevator could manoeuvre alongside by jacking up or giving slack using the steam powered winches attached to the elevators deck. The absence of a propulsion system also meant that elevators had to be moved around the port area by means of tugboats, towing the elevators from ship to ship.

The operating of a grain elevator stood under the supervision of two separate authorities who had to cooperate closely. Firstly, the transshipment process from start to end, and the handling and delivery of the product was the responsibility of what was plainly called the "elevator's boss". He coordinated work in the engine room, the boiler room, suction tube operation, the weighing room and deck activities, and made sure the buyers' and sellers' representatives enjoyed a pleasant stay on board. He administered the crew, its working hours, and which cargo was unloaded, carefully noting the name and origin of the unloaded bulk carrier, and the name and destination of the loaded vessel and its client. Furthermore, he was responsible for small on-board reparations to machines and installations. Apart from using the crew's compartments belowdecks, he usually had a small private office below decks to his disposal, where the elevators administration was stored, along with its needed official documents, such as steam authorities' permits and maintenance and fuel schedules.

Secondly, being a marine vessel, every elevator needed to be supervised by a marine authority, a skipper. The skipper was responsible for the elevator's movements in port

⁴⁰ Personal account of one of the operators of the engine room at Stadsgraanzuiger 19.

waters. He coordinated towage movements and was responsible for safety onboard concerning marine and port regulatory prescriptions. Moreover, he was responsible for getting the crew onboard before and onshore after shifts. In return for these services, the skipper was permitted to live on board with his family in the skipper's quarters, especially designed for this purpose. The skippers living quarters were accessible through deck doors, leading to a three-bedroom space with a kitchen and a dining room. By contemporary housing standards of the 1920s-1950s, and especially by the living standards on ships both inland and sea going, the skipper's quarters were far from minimal.⁴¹ It is not unheard of that storage rooms on deck were accompanied by a chicken's coop, and toilet facilities were nearby, a luxury that was not even integrated as a standard in housing onshore at that time. On the other hand, the skipper's family had to tolerate the noise coming from the adjacent engine room, and the often dusty environment in which the elevators operated. Keeping the living quarters free from dust from cargo and coal was an ongoing challenge, living conditions could be moist by the condensed steam produced by the engine.⁴² Remarkably, when in demonstration and open for public, Stadsgraanzuiger 19 nowadays regularly gets visited by people who memorize their youths growing up on an elevator, often accompanied by displaying intense feelings of nostalgia.

The 19 in fleet of elevators in Antwerp

In the port of Antwerp, the implementation of mechanised grain transshipment also met fierce resistance.⁴³ Contrary to the Rotterdam situation, where private investors initiated the purchase of the elevators, in Antwerp the port infrastructure was and still is exploited by the Port Authorities controlled by the city council. To prevent a competitive disadvantage, the city council ordered its first elevator at Luther A.G. in 1910.⁴⁴ The approximately 4000 dock workers protested heavily, but as the implementation of grain elevators resulted in an increase in volume of grain trade and transshipment, eventually the resistance broke. In November 1910 City Grain Elevator 1 delivered its first load, only to be decommissioned in May 1967, after an impressive lifespan of 57 years.⁴⁵ In 1933 the fleet consisted of 24 grain elevators, mainly operating in the America Dock besides the storage houses built by the grain trade company *Antwerp Grain Work Company*, later *SAMGA*. Amongst those 24 elevators was Stadsgraanzuiger 19.

After the building of the barge and tower and assembling the steam engine and the boiler on Shipyard Cockerill in Hoboken, the 19 was added to the cities fleet of floating grain elevators on July 7th, 1927. Two more steam powered elevators, numbers 20 and 21, follow soon after. In 1928, at the ordering of no. 22, the steam powered propulsion was replaced by diesel fuelled engines.⁴⁶ So, from 1928 onwards, diesel powered elevators worked alongside steam powered elevators in the port of Antwerp. This continued until the 1950s,

⁴¹ GEM, "De Does", 19.

⁴² Idem.

⁴³ De Vriese, "De vlottende graanzuiger", 13.

⁴⁴ Ibidem.

⁴⁵ Janse, Van den Ende, "Stadsgraanzuiger 19", 105.

⁴⁶ Ibidem.

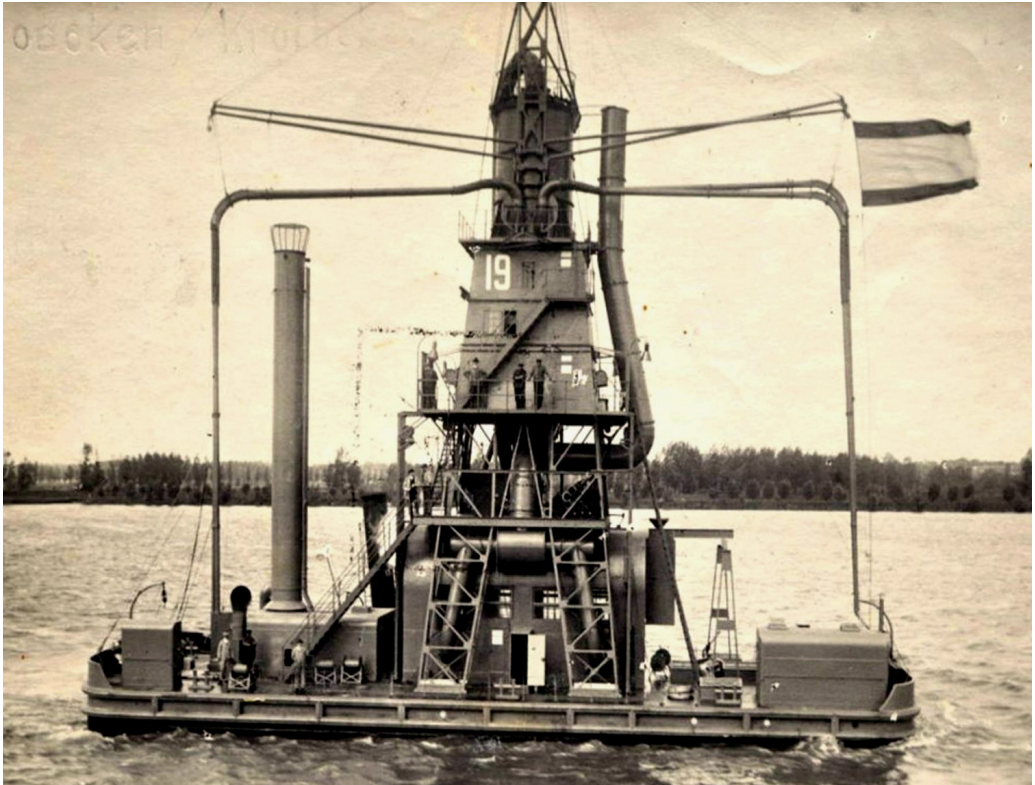

Image 4. Transfer of the 19 from Shipyard Cockerill, Hoboken to the Antwerp port authorities.
Source: Archive Stichting Rotterdamse Graanelevator.

when the city council ordered two elevators to be refitted from steam propulsion to diesel. Apparently, after the refitting of the 17 and the 18, together with the commissioning of newbuild orders, the fleets' capacity was adequate, because the 19 escaped modernization and remained operating on steam power.⁴⁷ In 1964 however, the original boiler was replaced by a 15 m³ boiler taken from no.12, which was built in 1947 by Shipyard *Verschure* in Amsterdam.⁴⁸ This boiler remains operational until the present day, and has, after inspection by the Dutch marine authorities, been granted license for operation for another 25 years in 2017.

After the boiler replacement, the 19 was put back in service again in 1965. However, from this moment onwards, the elevator fleet exploited by the Antwerp Port Authorities increasingly came under pressure. Contrary to the Rotterdam situation, where the elevators were exploited by the privately owned company GEM who had a near monopoly on grain transshipments,⁴⁹ the port of Antwerp was the scene of fierce competition by a few large grain

⁴⁷ Ibidem.

⁴⁸ Idem, 107.

⁴⁹ Only in the first decades (1908-1920) there was some competition. GEM, "De Does", 14.

trading companies who were dependent on the city owned elevators for transshipment.⁵⁰ In 1964 however, the Belgian grain trader *SoBelGra* was granted a monopoly by the city council on the unloading of fully loaded bulk cargo ships using its own land fixed elevators, leaving ships who were only partially loaded with grain for the fleet owned by the city.⁵¹ In the decades following, this pushed the city's elevator fleet slowly into the fringes of grain transshipment. Where in 1962 and 1963 the city's elevators transhipped 3 million tonnes annually, the amount of grain transported in 1982 decreased to a mere 80.000 tonnes. Also, transport over land due to the rise of France as a grain producer reduced the need for transportation by ship.⁵² Additionally, as was also the case in Rotterdam, economy of scale in transshipment started to compete with the once revolutionary elevators; large cranes, scooping up 15 tonnes of grain in one hoist outdated the elevators on their turn.

To mitigate these challenges, several measurements were taken by the Antwerp City council. To cut costs, the permanent residency by a skipper was abolished in 1966. In the same year, the number of crewmembers was reduced to six on steam powered elevators, and to four on diesel powered elevators.⁵³ To facilitate these reductions, the elevators had to be modernised. Firstly, the installation of electrical systems on the elevators reduced the need for deck crew by electrifying the windlasses for suction tube operation. Secondly, the boilers were adapted to be fuelled by gasoline instead of coal. Coal storage rooms were replaced by large gasoline tanks, adding to the overall fuel capacity, and reducing the number of bunkering moments. Moreover, fuel input, control and distribution in the boilers was electrified, so building up pressure with steam inside the boilers became a mechanized process, reducing the need for hard manual labour that was required for coal fuelled boilers.⁵⁴ In the early 1970s, propelled by the need for modernization and rationalisation, the steam powered elevators built in the beginning of the century became a remarkable but fascinating amalgam of old and new technology.

The 19 underwent these modernisations in 1971, after which it was commissioned again. However, the modernisations in the use of fuel proved to be counterproductive, because after the first oil crisis in 1975 the gasoline prices rose sharply. As a result, the number of operational elevators in Antwerp was reduced again. In 1982, only five elevators were still in operation; the diesel powered 17, 22, and 23, and the steam powered 19 and 21.⁵⁵ From 1978, the steam powered elevators had been on standby,⁵⁶ for reasons which proved the longevity of steam powered elevators coming to an end. Namely, whereas diesel powered engines could be turned on and off instantly, steam engines needed to be heated and fuelled permanently. Starting up a steam engine is a slow process. Too large discrepancies in temperature within the machine could cause hot steam to condense too early in the

⁵⁰ R. Baetens, A. de Vos, *Antwepens maritiem verleden* (Antwerp, 1990) 157; P. Daeleman, "Het belang van Antwerpen als graanhaven in de 2^e helft 19^e en 1^e helft 20^e eeuw", in: P. Lombaerde (ed.), *HistoriANT. Jaarboek voor Antwerpse geschiedenis* no. 5 (2007) 69–98.

⁵¹ De Vriese, "De vlottende graanzuiger", 19.

⁵² Agentschap Onroerend Erfgoed 2020: Stadsgraanzuiger 19 <https://id.erfgoed.net/erfgoedobjecten/305804> (01-10-2020).

⁵³ De Vriese, "De vlottende graanzuiger", 17–19.

⁵⁴ Agentschap Onroerend Erfgoed 2020: Stadsgraanzuiger 19 <https://id.erfgoed.net/erfgoedobjecten/305804> (01-10-2020).

⁵⁵ Agentschap Onroerend Erfgoed 2020: Stadsgraanzuiger 19 <https://id.erfgoed.net/erfgoedobjecten/305804> (01-10-2020).

⁵⁶ Janse, Van den Ende, "Stadsgraanzuiger 19", 107.

pipes and steam chests, blocking the movement of machine parts and even destroying it. Condensed water, in contrary to steam, cannot be compressed, and can create destructive blockages. Preparing a steam powered elevator for operation safely, could take up -and still does- a few days to a full week. This meant that remaining in operation, the steam powered elevators had to be fuelled constantly. Without the reassurance of a constant supply for transshipment and earning some revenues on the one hand, and high fuel prices on the other, the early 1980s situation in Antwerp was just not viable anymore.⁵⁷ On May the 24th of 1984, the 19 was decommissioned after being a full 57 years in service. After their decommissioning in 1985, the Antwerp city council decided that one of the steam powered elevators should be preserved as maritime heritage for later generations. The 19 and the 22 were parked in a corner of the port of Antwerp, awaiting the decision which one was going to be the candidate for preservation.⁵⁸ The other elevators were demolished.

Choices in preservation

Concomitantly, also in Rotterdam the elevators became increasingly outdated. In 1964, the GEM had opened a new location in the Botlek Harbour, which was built closer to the open sea and thus was accessible for larger bulk carriers. Later, in 1978, an even larger location was opened in the Europort Harbour. Although floating elevators were still used to unload bulk carriers upstream, they were increasingly modernised and upscaled in size and capacity. In 1978, the GEM-83, the most recent built elevator with a capacity of 800 tonnes per hour was commissioned during the celebratory opening ceremony of the new Europort location.⁵⁹ To illustrate progress, the oldest steam powered elevator the company possessed, the GEM-4 which was built in 1908, was moored besides the latest GEM-83, overarching 70 years of grain transshipment history. During the ceremony, the old GEM-4 was donated for preservation to the *Stoom Stichting Nederland* (Dutch Steam Foundation) and shipped to its old site -the Maas Harbour- awaiting its restoration.⁶⁰ In the late 1980s, three steam powered elevators were awaiting a second life as an object of European maritime heritage; the GEM-4 in Rotterdam, and the city owned elevators 19 and 21 in Antwerp. The rest of both fleets was demolished or sold for scrap, along with all other elevators in other European ports.

Restoring old steam powered elevators is a capital-intensive activity. To reduce costs, the Dutch Steam Foundation placed the GEM-4 into the care of a second foundation, which connected the preservation of maritime heritage with the goal of counterbalancing rising unemployment numbers due to the economic crisis of the 1980s.⁶¹ The *Stichting Industrieel Erfgoed Rijnmond* (Rijnmond Foundation for Industrial Heritage) published its first study on the GEM-4 in 1985, trying to win the hearts and minds of potential participants in financing the project.⁶² Moreover, it was the objective of the Rijnmond Foundation to initiate an outdoor museum in maritime heritage in the Leuve Harbour in the inner city of Rotterdam,

⁵⁷ De Vriese, "De vlottende graanzuiger", 19.

⁵⁸ De Vriese, "De vlottende graanzuiger", 19.

⁵⁹ GEM, "De Does", 42.

⁶⁰ Janse, Van den Ende, "Stadsgraanzuiger 19", 107.

⁶¹ Idem, 108,

⁶² Stichting Industrieel Erfgoed Rijnmond, *GEM-4, een levend monument* (Rotterdam, 1985). Archive SRG.

Image 5. The 19 and the GEM-4 awaiting inspection in Rotterdam. Source: Archive Stichting Rotterdamse Graanelevator.

adjacent to the new building of the *Maritime Museum Prince Hendrik*, currently named Maritime Museum Rotterdam.⁶³ However, already early in the GEM-4 restoration project, a major problem presented itself: with all other elevators being destroyed, how could the machine parts that were damaged or worn out beyond repair be replaced? The solution was found in the two elevators in Antwerp, both awaiting a destination of their own.

The Rijnmond Foundation approached the Antwerp city council with an offer for the purchase of one of the elevators, which was approved in April 1985.⁶⁴ The 19 was sold to the Dutch for the sum of 724.000 Belgian Francs, which in 2020 would be the equivalent to approximately €20,000. On the 25th of April, the 19, together with two antique port cranes to be restored and curated by the new outdoor museum, was towed over the Scheldt River towards Rotterdam, to be harvested for components and parts in the restoration of GEM-4. The 21, remaining in Antwerp, was assigned a few months later to the *National Shipping Museum* in Antwerp. Unfortunately, docked while waiting for a permanent location for public exhibition, the 21 fell victim to theft and vandalism, leaving it in such a deplorable state that it eventually was sold for scrap in 1998.⁶⁵

Soon after the arrival of the port cranes and the 19 in the Leuve Harbour in Rotterdam, the Rijnmond Foundation ceased to exist. Its objectives were met, and together with several other purchases and donations, the first objects for a museum on maritime heritage were

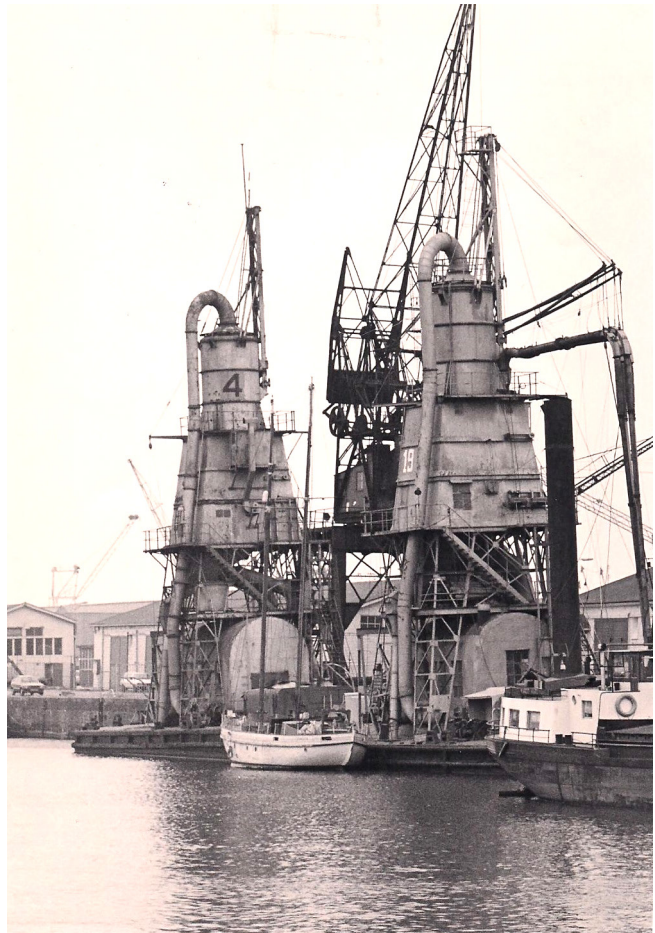

⁶³ Stichting Rotterdamse Graanelevator, P. Janse, *Elevator 19. Een nadere beschrijving* (Rotterdam, 2000) 3. Archive SRG.

⁶⁴ Agentschap Onroerend Erfgoed 2020: Stadsgraanzuiger 19. <https://id.erfgoed.net/erfgoedobjecten/305804> (01-10-2020).

⁶⁵ De Vriese, "De vlottende graanzuiger", 19.

collected. To manage restoration and preservation correctly, several objects were assigned to foundations operating under the overarching organisation of the new *Port Museum*.⁶⁶ In case of the elevators, the *Stichting Rotterdamse Graanelevator-SRG* (Rotterdam Grain elevator Foundation) was established by volunteers who took an interest in the preservation of the GEM-4. However, inspection revealed that the Antwerp elevator purchased for its spare parts appeared in significant better shape than the object to be restored, the GEM-4. Consequently, the plans were reversed; the Antwerp 19 would be preserved, using parts of the GEM-4. Furthermore, it was agreed that the project would be a joint effort by the SRG and the Port Museum. Crew recruitment, small repairs and day-to-day operation would be the responsibility of the SRG, while the Port Museum would organize and finance the complex replacement works and dockings. This *modus operandi* proved such a viable arrangement that the Maritime Museum Rotterdam prolonged, when it incorporated the Port Museum in September 2014. The arrangement is working until the present moment.

Restoration of the 19

In October 1987, the volunteers of the SRG started working on the renovation of the 19, or better put: started cleaning debris. Weekly, on Wednesdays and Saturdays the team of volunteers worked with great enthusiasm, soon to become a tradition which is still honoured in present times. Virtually everything inside and outside the 19 needed revision. Priority was to clear a safe passage for visitors onboard. In the search of sponsoring and new volunteers the 19 had to present itself not only in its home port Rotterdam, but also on the many maritime and industrial heritage events that are celebrated in The Netherlands.

In 1988, not yet operational but made presentable, the 19 participated in one of Europe's largest steam engine event *Dordt in Stoom*.⁶⁷ For two days the 19 was open for visitors. More than 2500 people stepped onboard to be shown around and educated by the volunteers about the history and the operation of elevators.⁶⁸ In the same year, the elevator was docked for much needed inspection and maintenance of its outer skin plates. Two years later, the 19 including its crew of volunteers was towed to Amsterdam to represent Rotterdam in the famous maritime event *Sail Amsterdam*, celebrated every five years. In the meantime, preservation work continued. In 1992, after a difficult restoration process followed by a thorough inspection of the Dutch Steam Authorities, the boiler was fired up for the first time in its new life, and the steam engine was put to operation again.⁶⁹ In 1993, during a small-scale demonstration, grain was transhipped again. The 19 was once more fully operational, which it remains until present day. Furthermore, in 1997 the SRG celebrated its 10 years anniversary in the newly renovated living quarters, modelled after photographs and memories from the 1950s. Ten years later, the 19 and its crew visited a maritime event in Antwerp, welcomed by former Belgian workers in grain transshipment and their families, celebrating the return of the 19 in her hometown.⁷⁰ In 2002, the efforts of the group of

⁶⁶ Janse, Van den Ende, "Stadsgraanzuiger 19", 108.

⁶⁷ Ibidem.

⁶⁸ Janse, Van den Ende, "Stadsgraanzuiger 19", 108.

⁶⁹ Idem, 114–115.

⁷⁰ https://www.siwe.be/files/publicaties/nieuwsbrieven/nb_36%20-%2037_2007_11_12.pdf (01-10-2020).

Image 6. The 19 under construction.

Source: Archive Stichting Rotterdamse Graanelevator. Photo: P. Janse.

volunteers got rewarded when the 19 was registered officially as Dutch maritime heritage.⁷¹

Keeping such a unique object operational and safe for its volunteers and the visiting public poses various challenges. Firstly, knowledge of the mechanics and the operation of steam engines in general, the 19's engine in particular, is increasingly the domain of people who worked with the technique during their professional lives. The 19 for that matter is exemplary for many maritime and industrial heritage objects. One of the engine operators, a volunteer who was involved from the start in 1987, is a pensioner who worked in the GEM's grain elevators engine rooms his entire life. Thus, knowledge

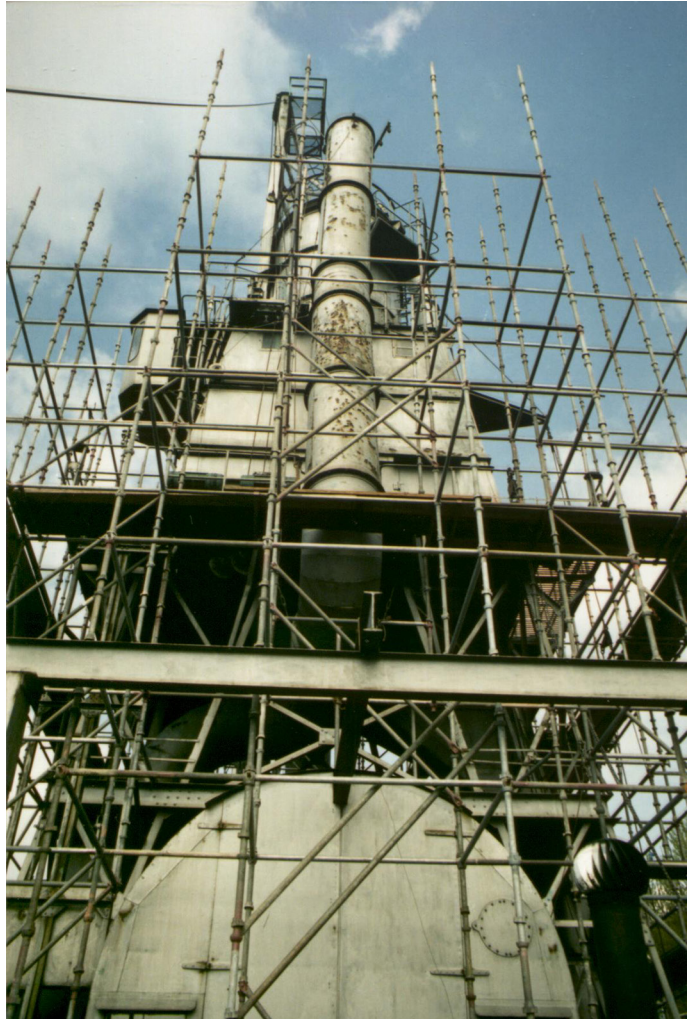

of operating the machine is solely transferred to other volunteers as tacit knowledge. It is hardly possible to codify the complex intertwining processes of building up boiler pressure, and heating and starting the machine. Apart from the technical procedures, based on his lifelong experience the operator hears or smells whether anything is wrong. He “feels” the machine. Getting acquainted with the technical procedures is one thing, hearing, seeing and most important of all recognising irregularities is another. Because the 19's steam engine is only operational during events due to high fuel costs, building up experience is a problem for new volunteers, which is closely connected to the second pending problem: the average age of the volunteers is increasing rapidly. The crew consists for the largest part of

⁷¹ Stichting Rotterdamse Graanelevator, *Annual report 2002* (Rotterdam, 2003) 4. Archive SRG. See also: [http://www.mobielecollectienederland.nl/nrme/object.php?tabel-nrme_standandaard&id=57&pt=Graanelevator_19_\(22590_BR_1996\) \(01-10-2020\)](http://www.mobielecollectienederland.nl/nrme/object.php?tabel-nrme_standandaard&id=57&pt=Graanelevator_19_(22590_BR_1996) (01-10-2020)).

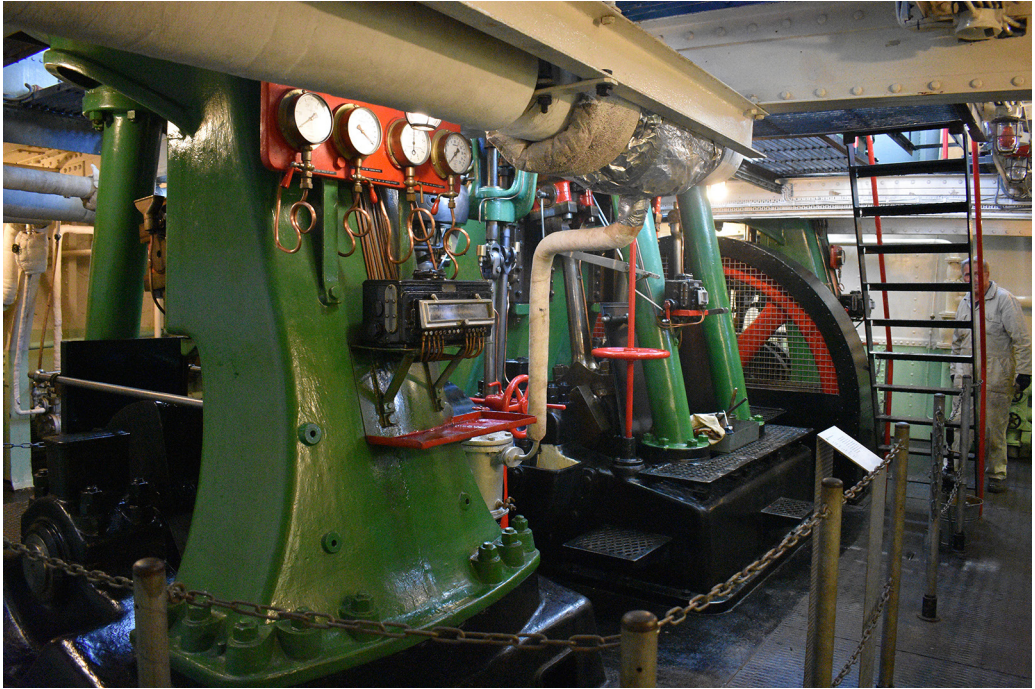

Image 7. The fully restored engine room of the 19. Photo by author.

pensioners in their 70s and 80s. Finding new and younger crew volunteers who want, or even can spend the time for regular maintenance and learn to operate the elevators steam engine is highly challenging. The common shared fear is that crucial knowledge will be lost after the current volunteers inevitably get too old to perform the physically challenging maintenance duties. Without operational knowledge, risks are the 19 becoming just 450 tonnes heavy dead weight, without the ability to demonstrate and educate – and entertain- the public. The SRG and the Maritime Museum Rotterdam are very aware of these challenges and have, over time, initiated different experiments to preserve knowledge and to recruit new crew members. Occasionally, new volunteers present themselves, but it proves exceptionally difficult to maintain long lasting volunteering relations. The handful of volunteers enrolled during recent years, as well appreciated as they are, do unfortunately not compensate for the attrition.

The transfer of knowledge and the pending crew shortage are not the only challenges the SRG and the Maritime Museum Rotterdam face. As a maritime object, curating the 19 presented other problems than usually encountered by museums curating objects of cultural heritage. Fully restored being one of the masterpieces of the museums historical collection, the 19 is moored in the outdoor museum port basin. It is thus exposed to the elements like any other ship and needs careful protection against rust and the unwanted nesting of birds, or worse, the corroding effect of bird feces. Moreover, due to the relatively proximity of the North Sea, the water in the Rotterdam inner city port area tends to silt in summertime when draught causes freshwater levels to decrease. This allows seawater to penetrate the

freshwater basins, adding to the natural iron corrosion which can cause the skin plates to lose one millimetre in thickness every ten years. So, notwithstanding the efforts of the crew of volunteers to maintain the 19 in an operational state, thirty years into her second life the last floating elevator needed a full and costly structural reparation. Repair works on the structural integrity of the 19 falls outside the technical capabilities of the volunteers, and outside the financial capabilities of both the SRG and the Maritime Museum. So, almost thirty years into her second life, a new threat has arisen to the survival of the 19. Although it was not yet expected for the immediate future, at one point in time patchwork on the outer skin plates will not keep the 19 afloat. To save Europe's last remaining floating grain elevator, a unique project of international cooperation in curating cultural heritage was designed.

The 19 today and in the future

In 2008, the Antwerp National Shipping Museum was closed. Its outdoor collection, consisting of various historical vessels and artefacts connected to Antwerp's history as a major Western European port city, was temporarily stored. Plans for an outdoor museum to display the vessels again did unfortunately not yet materialize. However, the indoor collection of the National Shipping Museum was transferred to the newly created *Museum aan de Stroom* (MAS), a futuristic building in the city's centre which opened its doors in 2011.⁷² A part of the permanent exhibition of the MAS displays Antwerp's maritime history as a port city, including some models of the once skyline dominating grain elevators. In the MAS, the Maritime Museum Rotterdam found a partner in an extensive and unique restoration plan of the 19.⁷³

In 2015, the museums applied for funding together at the trust Nature Preservation Father David, acting as steward for the legacy from the recently passed away port tycoon J. Choufour (1927-2014). During his life, Choufour had been an influential industrialist in the Rotterdam port area, before he spent his retiring years living in Belgium.⁷⁴ After his departing, he left his legacy into the hands of the trust, which by allocating significant amounts of funding grew out to be an important player in Dutch and Belgian cultural life. One of the trusts conditions for providing funding was that the 19 would obtain an official status in Belgian maritime heritage. To start the procedure of requesting historical validation at the Belgian authorities, at first the 19 would have to be present in Belgian waters for a continuous period of at least eight months.

Initially, when the plans were presented to the members of the crew, they were met with scepticism. After all, the 19 had called Rotterdam its home port for almost thirty years and was close to a second home for the crew, with its members acting as a surrogate family. Some crewmembers had been working on the 19s restoration and maintenance for decades, and now saw their beloved project taken away from them. The main concerns were that after the 19 was to depart from Rotterdam for such a long time, crew members would find

⁷² <https://www.mas.be/en/content/6-world-port> (01-10-2020).

⁷³ <https://bootmagazine.be/nieuws/mas-en-maritiem-museum-rotterdam-nemen-graanzuiger-19-onder-gesamenlijk-beheer/> (01-10-2020).

⁷⁴ <https://www.rijnmond.nl/nieuws/119009/Schoufour-betrokken-Rotterdammer-met-een-havenhart> (01-10-2020).

activities elsewhere, leading to the dissolution of the group. Moreover, the senior group members could remember very well how the 19's sister, the 21, was left poorly supervised in a corner of the Port of Antwerp, giving opportunity to theft and vandalism. In the meantime, the MAS and the Maritime Museum Rotterdam continued their negotiations, and involved the Antwerp city council in the negotiations, while meticulously informing the SRG on the progress made and plans crystallizing. Gradually, the initial scepticism of the crewmembers gave way to contemplation on how to take care for the 19 once she crossed the Belgian border.

After two years of negotiations and planning, on the 14th of October 2017 the 19 and its crew left the Leuve Harbour in Rotterdam and started her voyage to Antwerp. One day later she arrived at her previous home port and was moored in the oldest port basin in Antwerp, the Bonaparte basin next to the MAS.⁷⁵ Over the next months, warm relationships developed between the crew, the MAS, and a small group of Belgian volunteers who took it upon them to supervise the 19 in the crew's absence. The presence of the elevator drew a lot of attention of both local and national media, resulting in thousands of interested visitors during the days on which the working steam engines were presented to the public.⁷⁶ Especially heart-warming to the crew was the sight of an old man who showed his children and grandchildren where he had worked all his life, on the very 19. Moreover, promising contacts were made with some volunteers working in a small local museum in the nearby Hoboken, who informed the crew about the archives of the 19's builder, shipyard Naval Cockerill, which were kept undisclosed in boxes.

After the public events, the crew travelled regularly to the 19 now moored in Antwerp, keeping maintenance on schedule. Moreover, warm bonds were forged with Belgian colleague volunteers who were curating their own maritime heritage in Antwerp's port infrastructure. Also, the crew visited the shipyard where the 19 was built, currently building windmill foundations, and a first attempt was made to research the archives remaining in Belgium.⁷⁷ Thus, despite the volunteers' initial scepticism, Antwerp was eventually adopted by the crew as the 19's second home port. Meanwhile, the much-desired Belgian official status on heritage recognition was granted on the 17th of April 2018 by the Belgian ministry for Realty and Heritage,⁷⁸ by which the demands of the Father David Trust were met. It was agreed that after the pending major restoration, the 19 would alternately be present for fifty percent of the time in both Antwerp and Rotterdam.⁷⁹ The international restoration project is an unprecedented project in caretaking of European industrial and maritime heritage, preserving both the industrial history for Rotterdam as providing for the return of industrial heritage and history for Antwerp. By bringing the 19 back to her first home, the history on the Antwerp grain trade is no longer just a story.

At the moment of writing this article, the 19 is back in Rotterdam, where the crew and the Maritime Museum Rotterdam are busy preparing her second large renovation.

⁷⁵ <https://www.mas.be/nl/graanzuiger> (01-10-2020).

⁷⁶ <https://atv.be/nieuws/video-laatste-graanzuiger-ter-wereld-in-antwerpen-ik-kan-hem-niet-missen-57121> (01-10-2020).

⁷⁷ <https://felixarchief.antwerpen.be/> (01-10-2020).

⁷⁸ <https://www.sarovlaanderen.be/sites/default/files/atoms/files/Advies%20VCVE%2020%20oktober%202017%20bescherming%20Graanzuiger.pdf> (01-10-2020).

⁷⁹ <https://www.sarovlaanderen.be/sites/default/files/atoms/files/Advies%20VCVE%2020%20oktober%202017%20bescherming%20Graanzuiger.pdf> (01-10-2020).

Image 8. Exhibition of the 19 to the public during a maritime event. Source: Maritime Museum Rotterdam. Photo: T. de Man.

An extensive restoration plan has been written by a bureau specialised in restoring maritime heritage, based on which various shipyards are contacted for the job. Fortunately, some new crewmember enrolled, being very enthusiastic to be educated in the increasingly disappearing but essential knowledge of operating steam engines. In Antwerp, plans are made to educate an additional crew that can maintain and operate the 19 when she is located near the MAS. Meanwhile in Rotterdam, plans are made for branding the 19 as a masterpiece of industrial heritage, and new ways of presentation, education and involving the public are contemplated.⁸⁰ Currently it is not yet known what the timeframe of the restoration will be, nor are the financial consequences yet exactly known. It is highly likely that the 100th anniversary of the 19 in 2027 will be celebrated in good condition, keeping the history of the grain trade in both Antwerp and Rotterdam alive.



In conclusion

All over Europe, the preservation of operational industrial heritage faces problems as outlined in the previous paragraphs. A structural shortage is threatening the availability of volunteers, on which many curating institutions are dependent in keeping historic machinery

⁸⁰ R. Brand, "Overseas News from the Netherlands", in: Topmasts. The Quarterly Newsletter of The Society for Nautical Research no.35 (2020) 30-31. See also: <https://snr.org.uk/wp-content/uploads/2020/07/Top-masts-35-1.pdf> (01-10-2020).

running smoothly. This might potentially result in a brain drain of relevant knowledge to keep machines and installations operational. For the public, it is important not only to see the machines from the past, but also to witness them in operation. Just by looking at a steam engine alone the public does not come to an understanding of how it works, what efforts it takes to maintain such a machine, and in what sort of professions exactly they were used. In other words, not being operational, industrial heritage runs the risk of expiring into relics of the past, instead of demonstrating and telling living history by which the transitions of the past into the present might be better understood.

In 2015, the organisations involved with the preservation of the 19 saw a unique opportunity. However, cooperation was necessary, as no single organisation on its own merits could carry the financial responsibility for preserving the 19 for future generations. As a spin off to this project, new and unexpected projects arose. Knowledge and networks are shared between international groups of volunteers and new educational programs are being contemplated. Moreover, archives that remained hidden for decades were found and first preparations have been made for public disclosure. These spin off would not have come about if the institutions connected to the preservation of the 19 had decided not to cooperate and find new innovative ways in putting the 19's interests over their own. In an unprecedented international effort in planning, organisation, and cooperation, the SRG crew, the Maritime Museum Rotterdam, the Antwerp Museum aan de Stroom, and the Antwerp volunteers and city council secured grain elevator 19 for future generations, telling a part of the history of both cities in general, and about the grain transshipment industry in particular. The efforts of the parties involved can without any doubt seen as innovation in preservation, and perhaps are able to serve as an example, or at least an inspiration in solving unavoidable near future similar problems in the preservation of industrial heritage.



References

Literature

- Baetens, R.; Vos, A., De; *Antwerpens maritiem verleden* (Antwerp, 1990).
- Brand, R.; "Overseas News from the Netherlands", in: *Topmasts. The Quarterly Newsletter of The Society for Nautical Research* no.35 (2020) 25–31.
- Chochet, C.A.; *Het elevator-bedrijf in de Rotterdamse haven* (Rotterdam, 1933).
- Daeleman, P.; "Het belang van Antwerpen als graanhaven in de 2^e helft 19^e en 1^e helft 20^e eeuw", in: Lombaerde, P. (ed.); *HistoriANT. Jaarboek voor Antwerpse geschiedenis* no. 5 (2007) 69–98.
- Lente, D., Van; "Machines and the Order of the Harbour: The Debate About the Introduction of Grain Unloaders in Rotterdam, 1905–1907", in: *International Review of Social History*, No. 43 (1998) 79–109.
- Driel, H., Van; Schot, J.W.; "Het ontstaan van een gemechaniseerde massagoedhaven in Rotterdam", in: Lintsen, H.W.; Schot, J.W. (eds.); *Techniek in Nederland in de twintigste eeuw. Deel 5. Transport, communicatie* (Zutphen, 2002) 75–96.
- Driel, H., Van; Schot, J.W.; "Radical Innovation as a Multilevel Process: Introducing Floating Grain Elevators in the Port of Rotterdam", in: *Technology and Culture* 46, no.1 (2005) 51–76.

- Driel, H., Van; Schot, J.W.; "Regime-transformatie in de Rotterdamse graanoverslag", in: Nederlands Economisch Historisch Archief, Devos, G. (ed.); *NEHA-Jaarboek 64* (Amsterdam, 2001) 266–317.
- GEM, *De Does. Jubileumuitgave 75 jaar GEM* (Rotterdam, 1983).
- Janse, P.; Ende, K., Van den; "Stadsgraanzuiger 19", in: *Scheepshistorie 13* (Ede, 2012) 98–115.
- Smit, E.J.; *De syndicale onderstroom: Stakingen in de Rotterdamse haven, 1889–2010* (Amsterdam, 2013) 53–83.
- Stichting Industrieel Erfgoed Rijnmond, *GEM-4, een levend monument* (Rotterdam, 1985). Archive SRG.
- Stichting Rotterdamse Graanelevator, *Annual report 2002* (Rotterdam, 2003). Archive SRG.
- Stichting Rotterdamse Graanelevator, Janse, P.; *Elevator 19. Een nadere beschrijving* (Rotterdam, 2000). Archive SRG.
- Uyttenboogaart, D.L.; "Het graantransportbedrijf", in: *Gedenkboek Rotterdam 1328–1928* (Rotterdam, 1928) 277–297.
- Voogd, A.; *De graanelevators en de gisting in het havenbedrijf te Rotterdam* (Rotterdam, 1907).
- Vriese, K., De; *De vlottende graanzuiger* (Antwerpen, 2018).

Websites

- Agentschap Onroerend Erfgoed 2020: Stadsgraanzuiger 19 <https://id.erfgoed.net/erfgoedobjecten/305804> (01-10-2020).
- <https://atv.be/nieuws/video-laatste-graanzuiger-ter-wereld-in-antwerpen-ik-kan-hem-niet-missen-57121> (01-10-2020).
- <https://bootmagazine.be/nieuws/mas-en-maritiem-museum-rotterdam-nemen-graanzuiger-19-onder-gesamenlijk-beheer/> (01-10-2020).
- <http://dingler.culture.hu-berlin.de/article/pj325/ar325001> (01-10-2020).
- <http://dingler.culture.hu-berlin.de/article/pj329/ar329037> (01-10-2020).
- <https://felixarchief.antwerpen.be/> (01-10-2020).
- <https://id.erfgoed.net/erfgoedobjecten/305804> (01-10-2020).
- <https://snr.org.uk/wp-content/uploads/2020/07/Topmasts-35-1.pdf> (01-10-2020).
- <https://www.british-history.ac.uk/survey-london/vols43-4/pp356-374> (01-10-2020).
- <https://www.ebsbulk.nl/over-ons/geschiedenis/> (01-10-2020).
- <http://www.elevator19.nl/> (01-10-2020).
- <http://www.machinemuseum.nl/graaanzuiger.html> (01-10-2020).
- <https://www.mas.be/en/content/6-world-port> (01-10-2020).
- <https://www.mas.be/nl/graaanzuiger> (01-10-2020).
- <https://www.maritiemmuseum.nl/tentoonstellingen/graaanelevator> (01-10-2020).
- [http://www.mobielecollectienederland.nl/nrme/object.php?tabel=nrme_standandaard&id=57&pt=Graanelevator_19_\(22590_BR_1996\)](http://www.mobielecollectienederland.nl/nrme/object.php?tabel=nrme_standandaard&id=57&pt=Graanelevator_19_(22590_BR_1996)) (01-10-2020).
- <http://www.portcities.org.uk/london/server/show/conMediaFile.4857/A-grain-elevator-discharging-the-SS-Cornish-City-at-the-Royal-Victoria-Dock.html> (01-10-2020).
- <https://www.rijnmond.nl/nieuws/119009/Schoufour-betrokken-Rotterdammer-met-een-havenhart> (01-10-2020).
- <https://www.sarovaanderen.be/sites/default/files/atoms/files/Advies%20VCVE%2020%20oktober%202017%20bescherming%20Graanzuiger.pdf> (01-10-2020).
- https://www.siwe.be/files/publicaties/nieuwsbrieven/nb_36%20-%2037_2007_11_12.pdf (01-10-2020).